

# CraneKit for Monorail Systems and Jib-Cranes

12.2022



New in  
portfolio!

With its CraneKit for Monorail Systems and Jib-Cranes, STAHL CraneSystems offers crane builders worldwide the possibility to complete orders effectively and economically with little planning outlay. Thanks to simple configuration of the crane system in our in-house sales program SalesManager, users can easily select and coordinate the various components with each other. With the help of a detailed visualisation, you can immediately see what your system will look like. You obtain exact details regarding the technology and prices.

## Click a CraneKit

STAHL CraneSystems provides the intuitive planning software SalesManager with a continuously updated database, enabling access to the complete standard programme. The CraneKit consists of hoist, power supply, control pendant, terminal box, equipment box and other options, for example limit switch actuators, travelling stops and SMC Multicontroller.

## Equipment

As reliable, robust and safe hoist of high quality, you can choose from chain hoists as well as wire rope hoists with power supply. On request, the complete product portfolio is also available in explosion-proof design according to ATEX or IECEx. Optional risers and main switches can be selected.

# CraneKit for Monorail Systems and Jib-Cranes

## CraneKit version

The right or left version of the CraneKit is determined by the direction in which the operator looks at the power supply. In a left-hand CraneKit version, the feed point is on the left-hand side – optionally on the right. The electrical connection box and the trolley drive are on the opposite side of the power supply. The towing arm is on the drum side in the case of a wire rope hoist and opposite the trolley drive in the case of a chain hoist.

## Special solutions on request

- CraneKit for curved tracks, spur rails and bracket cranes
- Distance controls
- Integration of on-site slewing drive

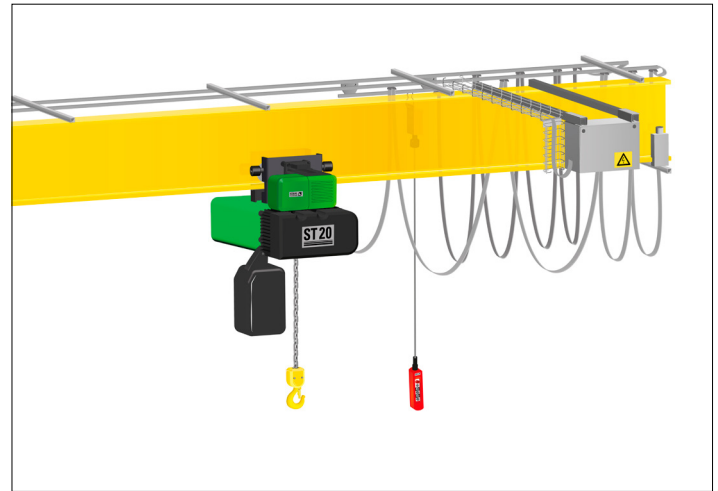
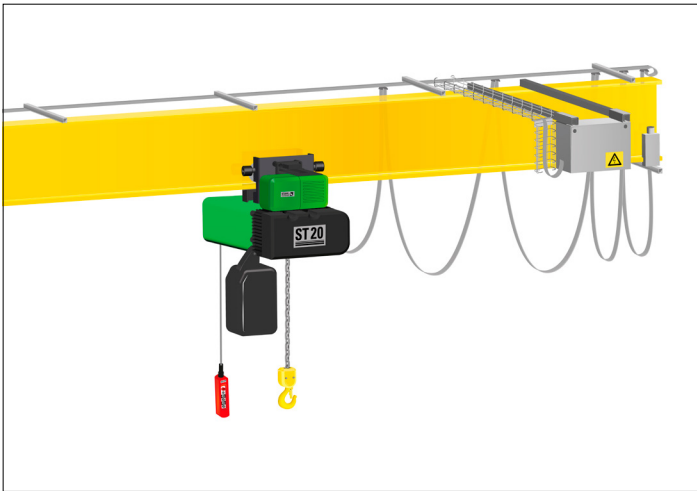

1

2

Monorail runway	Operation	Crane control
Electrical lifting and travelling	Control pendant on hoist, separately movable or radio-controlled	Terminal box
Electrical lifting with push trolley*	Control pendant on hoist	Terminal box
Jib-Crane	Operation	Crane control
Electrical lifting and travelling	Control pendant on hoist, separately movable or radio-controlled	Terminal box
Electrical lifting with push trolley*	Control pendant on hoist	Terminal box
Electrical lifting, travelling and slewing	Control pendant can be moved separately	Divided control
	Radio remote control without control pendant	
	Radio remote control with control pendant (movable)	
	Radio remote control with control pendant (not movable)	

\* Push trolley only for chain hoist

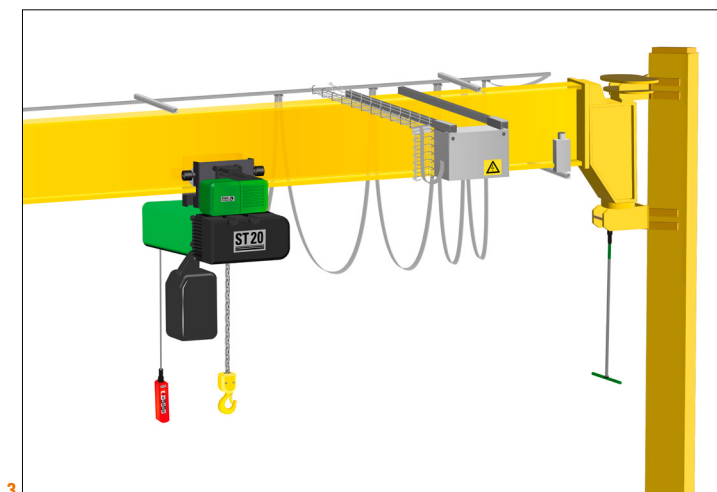

3

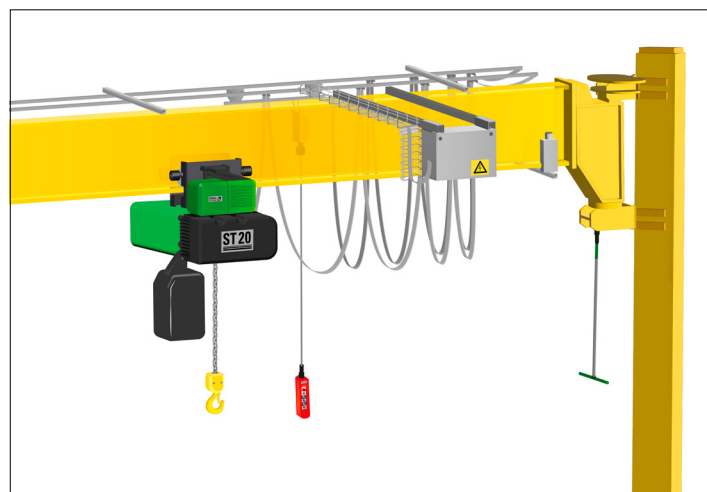

4

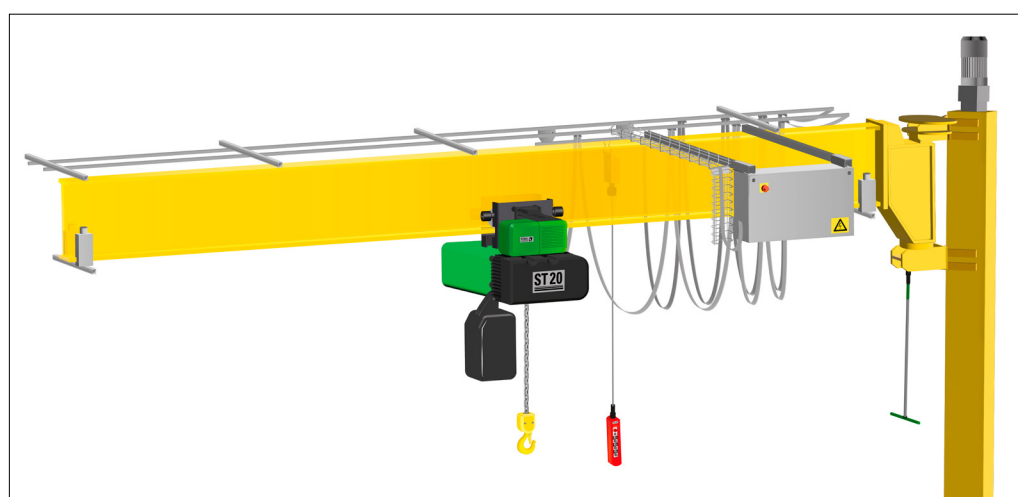
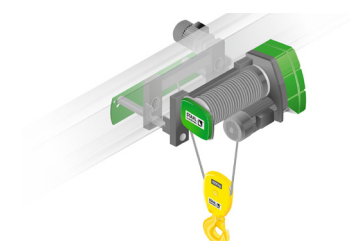

5

All CraneKit versions can also be configured with a wire rope hoist in SalesManger.

- 1 Control pendant on hoist
- 2 Control pendant separately movable
- 3 Control pendant on hoist
- 4 Control pendant separately movable
- 5 Divided control for on-site slewing drive, control pendant separately movable

	Standard	Options
Ambient temperature	-20 °C to +40 °C	To +55 °C
Environment	Indoor	Outdoor
Explosion protection	-	ATEX or IECEx
Runway length	To 40 m	Longer runway lengths on request
Control pendant	Control pendant moves with hoist	Radio remote control or radio remote control with emergency control pendant
	Control pendant can be separately movable	
Hoist drive	2-step	Frequency controlled
Hoist types	Chain hoist	All hoist options
	Wire rope hoist	
Plug-and-Play	The control pendant on the hoist is pluggable. On the Jib-Crane with distributed control, the main power supply is pluggable up to 16 mm².	-



You can find this and other brochures at [www.stahlcranes.com/download](http://www.stahlcranes.com/download). We will gladly send them to you by post.

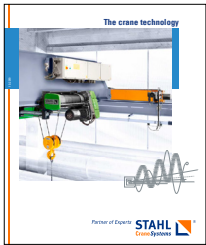
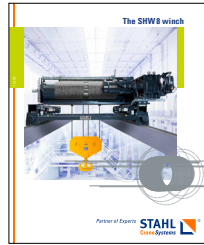

Presented by

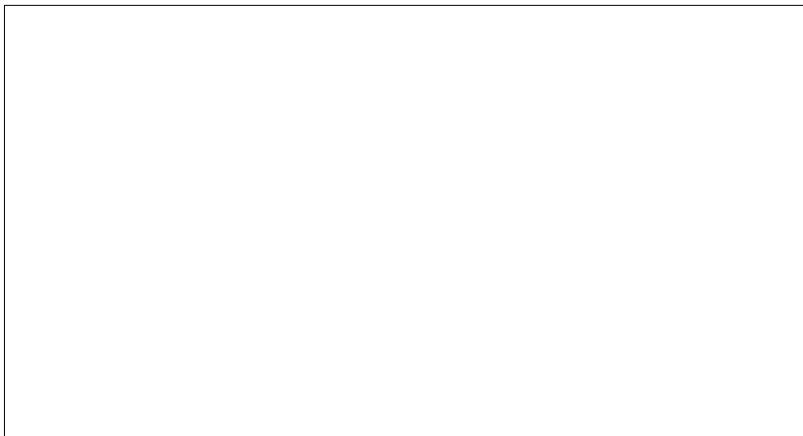

STAHL CraneSystems GmbH  
Daimlerstr. 6, 74653 Künzelsau, Germany  
Tel +49 7940 128-0, Fax +49 7940 55665  
[marketing.scs@stahlcranes.com](mailto:marketing.scs@stahlcranes.com)  
[www.stahlcranes.com](http://www.stahlcranes.com)

