

WIRE #	AWG*	DEVICE CONNECTED
40L41	14-BLK	X40.1 F44, U40
40L42	14-BLK	X40.1 F45, U40
40L43	14-BLK	X40.1 U40
40L44	14-BLK	F44, K49
40L45	14-BLK	F44, K49
40L49	14-BLK	K49, U40
40L110	16-RED	X40.2 U40, S420
411	16-RED	X40.2 S420
40L421	18-RED	X40.2 S420, U40
412	16-RED	X40.2 S420
40L422	18-RED	X40.2 S420, U40
40L415	18-RED	X40.2 U40
40L423	18-RED	X40.3 U40
40L426	18-RED	X40.3 S420, U40
40L427	18-RED	X40.3 S420, U40
40L49	16-RED	U40, SA
40L100	16-WHT	X40.3 K49, SA, U40
L491	X40.3	U40
L492	X40.4	U40, R491
L493	X40.3	NOT USED
L494	U40, R491	
R40.1	14-BLK	U40
R40.2	14-BLK	U40
40L47	14-BLK	X40.4 K49, G41
40L48	14-BLK	X40.4 K49, G41
U41	14-BLK	X40.4 M41, U40
M41	14-BLK	M41, U40
M41	14-BLK	M41, U40

TIGHTENING TORQUE 12 LB.-IN. FUSE BASE TERMINALS TIGHTENING TORQUE 20 LB.-IN.

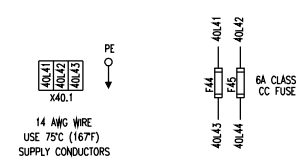

TIGHTENING TORQUE 7 LB.-IN.

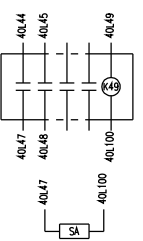

CONNECT TO HOST A16 PANEL CONTROL CIRCUIT AND TROLLEY BRANCH CIRCUIT OCP CUSTOMER SUPPLIED DISCONNECTING MEANS AND FEEDER OCP  
TROLLEY OCP RATINGS:  
15A MAX. TIME DELAY CC-CLASS FUSES OR  
15A MAX. LISTED THERMAL-MAGNETIC CIRCUIT BREAKER

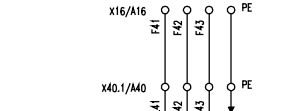

### ELEMENTARY DIAGRAM

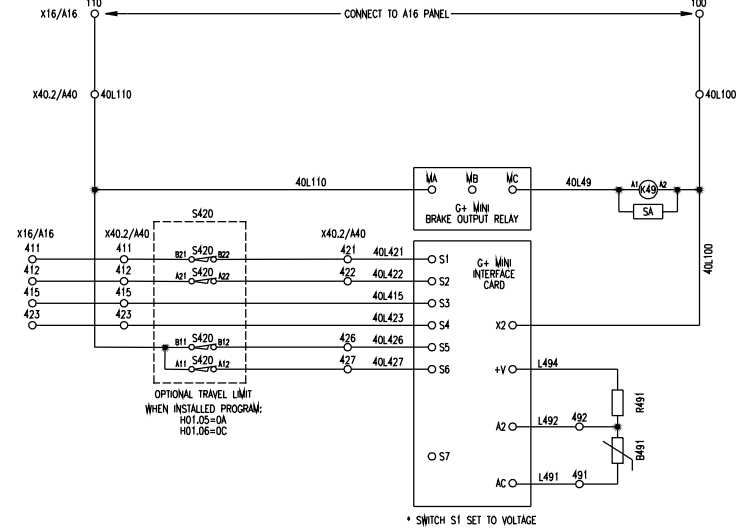

\* SWITCH S1 SET TO VOLTAGE

UL508A TROLLEY CONTROL PANEL	
VOLTAGE	460V
PHASES	3 PH.
FREQUENCY	60 Hz
TOTAL FLA	5.5A
LARGEST MOTOR FLA	5.2A
LONGEST MOTOR TIME RATE	6 MIN ON-4 MIN OFF (IEC 60% DUTY)
SCCR (kA)	5kA
MAX FUSE	15A
MAX CIRCUIT BREAKER	15A
MAX VOLTAGE	460V
ENCLOSURE TYPE	4 / 12
INPUT TERMINAL ID	X40.1: 40L41, 40L42, 40L43
WIRING DIAGRAMS	45661006

#### NOTES:

\* WIRE AWG IN THIS COLUMN APPLIES TO WIRING INTERNAL TO HOST CONTROL PANEL. FIELD WIRING REQUIREMENTS ARE SHOWN BELOW APPROPRIATE TERMINAL BOARD.

TO MAINTAIN ENCLOSURE TYPE 4, TYPE 12 RATING OF THE ENCLOSURE, USE CONDUITS AND SEALING FITTINGS WITH A TYPE 4 AND TYPE 12 RATING.

ALL PANEL COMPONENTS MUST BE LABELED TO MATCH SCHEMATIC WIRING DIAGRAM DESIGNATIONS.

USE COPPER CONDUCTORS ONLY FOR ALL FIELD TERMINALS.

SINGLE TERMINAL GROUND LUG PROVIDED FOR SUPPLY GROUNDING CONDUCTOR ONLY. DO NOT USE FOR PANEL WIRING.

LABEL FUSE BASES WITH FUSE SYMBOL AND SIZE IN AMPERES USING A PRINTED LABEL.

ADJACENT TO TRANSFORMER LABEL FUSE SYMBOL AND AMPACITY.

LABEL TERMINAL BLOCKS WITH ALPHANUMERIC CODE AS SHOWN ON WIRING DIAGRAM USING PERMANENT MARKER.

NOTE: THIS WIRING DIAGRAM SHOWS WIRING FOR 3 SPEED CONTROL. PROGRAMMING OF THE INVERTER CAN CHANGE THE CONTROL METHOD TO 2-STEP, 3-STEP, 2-STEP INFINITELY VARIABLE, OR 3-STEP INFINITELY VARIABLE.

**WARNING:**  
THIS EQUIPMENT MUST BE EFFECTIVELY GROUNDING ACCORDING TO APPLICABLE CODES.

**AVERTISSEMENT:**  
CET EQUIPEMENT DOIT ETRE MIS A LA TERRE EN ACCORDANCE AVEC LES NORMES EN VIGUEUR.

#### SYMBOL DESIGNATIONS

U40 - INVERTER  
R40 - DYNAMIC BRAKING RESISTOR  
F44 - BRAKE CIRCUIT FUSE  
F45 - BRAKE CIRCUIT FUSE  
K49 - BRAKE RELAY  
G41 - BRAKE RECTIFIER  
R491 - PTC BRANCH RESISTOR  
B491 - PTC THERMISTOR  
S420 - TRAVEL LIMITS  
SA - SURGE ABSORBER  
X20 - TERMINAL BLOCKS

POWER TERMINALS TIGHTENING TORQUE 10.6-13.3 LB.-IN.

INTERFACE CARD TERMINAL TIGHTENING TORQUE 1.1-2.2 LB.-IN.

TIGHTENING TORQUE 12 LB.-IN.

TIGHTENING TORQUE 12 LB.-IN.

TIGHTENING TORQUE 12 LB.-IN.

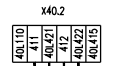

14 AWG WIRE USE 75°C (167°F)

\* REMOVE TERMINAL BOARD JUMPER WHEN TRAVEL LIMIT S420 IS PROVIDED

M41 MOTOR 460 VOLT 3.5HP/2.6W-120Hz 5.2 FLA THERMALLY PROTECTED TERMINALS L491 & L492

TIGHTENING TORQUE 4.5 LB.-IN.

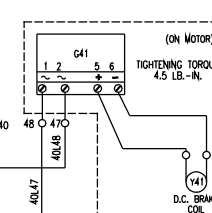

Y41 DC BRAKE 207VDC 84W 0.41A

MOTOR CONNECTION: CONNECT MOTOR FOR DELTA WINDING

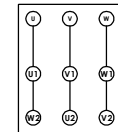

FIRST USED ON: PROJECT ONE

REV	DATE	DESCRIPTION	BY	CHKD
1	10/2018	INITIAL RELEASE	RTB	Drawn
2	-	-	-	Approved
3	-	-	-	Original Author
4	-	-	-	Prepared
5	-	-	-	None

**CISCO**  
Columbus McKinnon Corporation  
Waukesha, WI, USA

WIRING DIAGRAM - YK/SK HOIST  
4F18: TROLLEY WITH BRAKE  
G+ MINI VFD  
460V - A20 PANEL - UL508A

D 45661006

Sheet 1/1