

## Hydraulic jacks & tools

A characteristic of this “force-oriented” hydraulic programme is the operating pressure which can be as high as 700 bar. This guarantees a simple and safe generation of highest forces. In spite of this the units remain compact, portable and easy to operate. High-pressure hydraulic systems of this type are used in universal assembly and repair operations whereby their application in day-to-day operations is almost unlimited. The component programme allows the individual configuration of simple and also complex system solutions.

### They are used in the following main industrial areas:

Heavy industry, mining, shipbuilding, offshore, aviation industries, power stations, steel construction, steel making and processing, building construction, bridge and tunnel construction, heavy steel and tank construction, metal processing workshops, and many more.

## Table of contents

	Page
<b>Hydraulic cylinders, single-acting</b>	<b>358 - 367</b>
	<b>376 - 379</b>
<b>Hydraulic cylinders, double-acting</b>	<b>368 - 375</b>
<b>Accessories for hydraulic cylinders</b>	<b>380 - 383</b>
<b>Hand pumps 700 bar</b>	<b>384 - 389</b>
<b>Hand pumps up to 2000 bar</b>	<b>390</b>
<b>Foot pump 700 bar</b>	<b>391</b>
<b>Electric &amp; Pneumatic motor pumps</b>	<b>392 - 393</b>
<b>Electric hydraulic power packs</b>	<b>394 - 403</b>
<b>Valves &amp; Accessories</b>	<b>404 - 417</b>
<b>Puller</b>	<b>418 - 423</b>
<b>Jacks</b>	<b>425 - 430</b>
<b>Hydraulic jacks &amp; tools</b>	<b>431</b>
<b>Test rigs</b>	<b>432 - 433</b>
<b>Presses</b>	<b>434 - 436</b>
<b>Selection &amp; Speed charts</b>	<b>437 - 441</b>

## INFO

---

Please note our user instructions at the beginning of each chapter

# Yale

HYDRAULIC JACKS & TOOLS



# INFO

## Why hydraulics?

Hydraulics is the kind of power transmission which allows the greatest density of forces. There is no other kind of power transmission that will transmit comparable high forces with the same construction size.

## Hydraulic tools

Hydraulic tools are a special type of power tools, which can be used for general assembly and repair jobs with preferably high force in lowest spaces. Simple applications, clearness of the programme in line with robustness, short-term deliveries and universal operation possibilities have made Yale hydraulic components indispensable tools also for elaborate functions. The unlimited power of hydraulic tools is used in applications like lifting, levelling and positioning of heaviest loads, installations of machines, assembly of complex structures as well as in general repair of maintenance jobs. The components can also be operated in fixtures for clamping, testing, pressing, extracting, crimping, cutting, riveting and many more.

## How to reach high forces in hydraulics?

area	x	pressure	=	force
effective piston area	x	system pressure	=	force
cm <sup>2</sup>	x	bar	=	daN

### Example: Hydraulic cylinder YS-10/

14.3cm <sup>2</sup>	x	700bar	=	10010 daN
			=	100 kN
			=	10t

## Linear conversion of pressure force

The above formula shows that pressure forces can be converted linearly.

Example:

### A 10 ton cylinder presses at:

700 bar	-	100 kN	=	10 t
350 bar	-	50 kN	=	5 t
100 bar	-	14 kN	=	1.4 t
1 bar	-	0.14 kN	=	0.014 t

## INFO

The system pressure determines the force of the hydraulic cylinder. The oil displacement determines the piston travel speed.

## Basic terms in hydraulics

### Pressure

is the system pressure generated by the pump, which, however, can also be produced by an external power source, which acts on the hydraulic cylinder.

### Force

is always the pressure transferred by the hydraulic cylinder (only with counterpressure).

### Stroke

is the travel distance to be achieved by the force (no-load stroke, loaded stroke, return stroke).

### Piston travel speed

is the time, in which the piston of the hydraulic cylinder is to pass a certain travel distance (stroke) (no-load stroke + loaded stroke, return stroke).

### Hydraulic cylinders

are available in many different designs, however, with only two basic function principles:

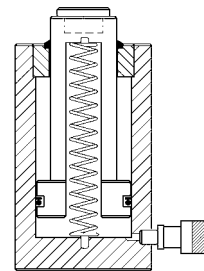

#### single-acting

The piston travel is achieved via hydraulic pressure and returned by spring activation (pressure build-up in one direction only).

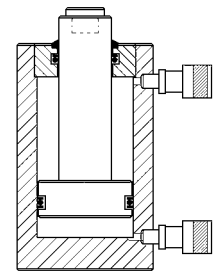

#### double-acting

The piston travel is achieved via hydraulic pressure in both directions. (Push forces and pulling forces are possible).



## Hydraulic hand pumps

The function of a hydraulic hand pump is to convey hydraulic oil (no-load stroke) and to generate pressure, which will be converted by the hydraulic cylinder into force (loaded stroke). Hydraulic hand pumps are independent from energy and can be used in every-day applications. They are easily portable and render an extremely high power generation in connection with a corresponding hydraulic cylinder.

Hand pumps require certain manpower and are often replaced by motor pumps in case of permanent duty and high oil quantities, respectively.

## Hand pumps are distinguished by:

1. Oil displacement volume (1st stage/2nd stage).
2. The function of the hydraulic cylinder: single-acting/double-acting.

## Motor pumps

transmit an oil flow as soon as the pump unit is driven by the electric motor. Contrary to hand pumps, the oil flow is also available when the hydraulic cylinder is not activated (e.g. during work breaks).



## Hydraulic valves

Valves are used in hydraulics to control the oil flow (generated by either hand or motor pump) in terms of direction, pressure and oil volume.

## Directional valves

are required to control the direction of the oil flow and thus the work motions of the connected hydraulic cylinder (**advance - hold - return**).

Depending on the type of pump and cylinder, 2-, 3- or 4-way valves may be employed.

3/3-way valves for single-acting cylinders

4/3-way valves for double-acting cylinders

Controls are available with either manual or electro-magnetic valves (the latter with remote cable control).

## Pressure valves

are employed to limit the system pressure in a hydraulic system or within a part of the oil circuit. Pressure valves or pressure relief valves are also installed as safety devices in order to avoid excessive increase of the system pressure beyond a given value.

## Shut-off and throttle valves

are used to easily shut-off hydraulic lines by hand. On account of their sensible control mode, these valves can also be applied to throttle an oil flow and thus to control the piston advance at both lifting or lowering of the load.

## Safety check valves

are used for those applications where pressure drops must be avoided.

## Pressure switch

can be set to any pressure value in order to switch on/off parts of the hydraulic circuit.

## For your safety

Hydraulic units are extremely robust and durable. Nevertheless you should observe the following instructions for your own safety and to increase the life expectancy of the product:

- Never exceed the max. pressure (capacity) of the hydraulic units.
- Avoid eccentric loading of the piston.
- The load must always be positioned centric and parallel on the piston. Avoid point loading!
- Never pass under a raised load, if this is not supported additionally.
- Hydraulic units must be kept clear of heat (e.g. during welding).
- Protect hydraulic hoses against damage and strong kinks. Hydraulic hoses should lie freely in a wide curve. Avoid tensile load.

## Eccentric loading

In order to obtain a long life expectancy, hydraulic cylinders series YS, YLS, YFS, YCS, YCH, YH and YPL are manufactured from chromium-molybdenum steel, the cylinder housings and piston rods are hardened and tempered and provided with bronze guides.

Generally, hydraulic cylinders should not be loaded eccentrically, as this can lead to reduced lifetime. In practice, a lateral loading cannot be fully avoided. In this case the maximum system pressure and the stroke of the cylinder should only be used by 50%. Ensure that the load always rests on the total area of the steel saddle and the piston, respectively. Also ensure that the entire bottom area of the hydraulic cylinder always stands on a level, sustainable ground surface.

This applies especially to flat cylinders!

## Repairs

Repair and maintenance should be performed by qualified personnel only. Make sure to use original spare parts only.

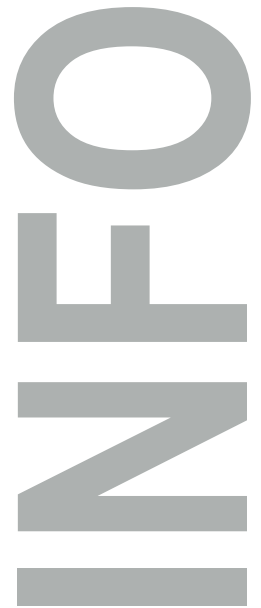

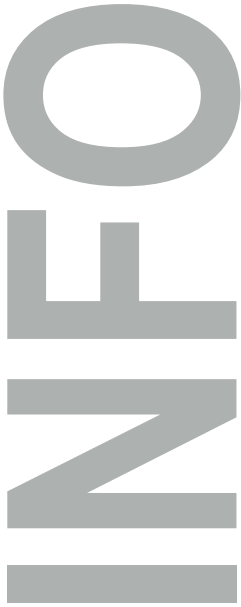

### Hydraulic cylinders with Yale Chro-Mo-Design

Yale hydraulic tools are designed for professional operation. A tool is only as good as its basic material. Therefore, our cylinders are manufactured from high quality chromium-molybdenum steel and are heat-treated.

#### Double bronze bearings

Practice has shown that hydraulic cylinders used as a tool in workshops or on construction sites are frequently subjected to eccentric loading. Yale hydraulic cylinders are provided with double bronze bearings on the plunger, which minimizes friction between plunger and body during lateral loading.

#### Hard chromium-plated piston

Offers excellent protection against mechanical damage and corrosion. Excellent sliding characteristics in conjunction with the upper bronze bearing in the stop ring.

#### Metric mounting threads and standard parts

To facilitate the installation of hydraulic cylinders in jigs and fixtures and auxiliary structures. The metric standard throughout the entire series simplifies service operations and repairs. Cylinders carry the full load even under maximum operating pressure.

#### Stop ring carries full pressure

As a safety factor the stop ring on all Yale hydraulic cylinders carries the full load even under maximum operating pressure.

#### Delivered ready to use

Yale hydraulic cylinders are delivered ready to use incl. female coupler half, hardened saddle and mounting threads; larger cylinders come with carrying handle or transportation lugs. This also applies to customised combinations which are always supplied fully assembled.

Hardened alloy steel saddle

Metric mounting threads in cylinder base, plunger and cylinder collar (depending on series)

Two bronze bearings minimize friction even in cases of eccentric loading

# INFO

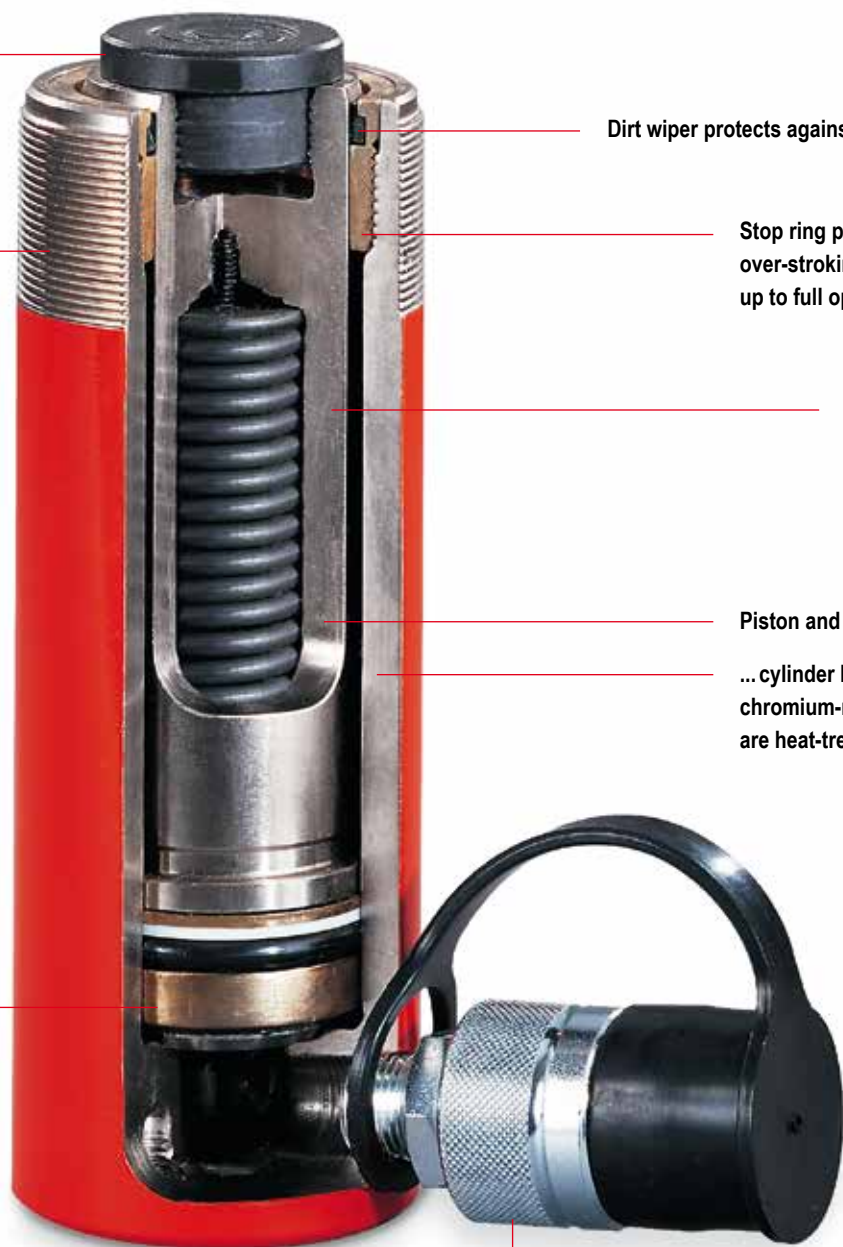

Dirt wiper protects against dirt

Stop ring prevents over-stroking of the piston up to full operating pressure

Hard chromium-plated plunger

Piston and ...

... cylinder housing are made from chromium-molybdenum steel and are heat-treated

Female coupler half CFY-1 (incl. dust cap)



## YS Universal cylinder

### Single-acting with spring return, capacity 5 - 100 t

Robust construction with long guides allows the units to withstand abuse and better tolerate eccentric and side loading, yet is convenient to use with only one quick-release coupler hose connection and a spring return.

Universal cylinders are designed for all jobs where high forces but compact dimensions are required: e.g. straightening steel constructions, removing parts like shafts, axles, lifting, positioning, weighing, supporting, testing as well as for all general assembly and repair applications. Due to the various mounting threads the cylinders can easily be installed in clamping devices, welding fixtures, frame presses etc.

#### Features

- Yale ChroMo-Design.
- Operating pressure max. 700 bar.
- Single-acting with spring return.
- Robust design with long piston bearings to withstand eccentric loading.
- Cylinder body and piston are made from solid chromium-molybdenum steel and heat-treated.
- Hard-chromium plated piston with replaceable, heat-treated saddle.
- Metric mounting threads on cylinder collar, in the base and piston rod (5 to 30 t).
- Stop ring can bear full capacity (pressure) and is fitted with dirt wiper.
- Interchangeable hardened saddle.
- Dirt wiper protects against dirt.
- Oil port thread 3/8 NPT.
- Incl. female coupler half CFY-1.
- YS-50/100 and YS-50/160 with carrying handle.
- YS-50/320 up to YS-100/200 with lifting rings.



## INFO

Selection charts "cylinder/hand pumps" can be found on pages 438 - 439.

Travel-speed charts are supplied on pages 440 - 441.

**Technical data YS**

Cylinder size	Model	Art.-No.	Capacity	Stroke	Effective plunger area	Oil volume max.	Closed height	Cylinder outside diameter	Weight
t			kN	mm	cm <sup>2</sup>	cm <sup>3</sup>	mm	mm	kg
5	YS-5/15	N11100001	50	15	7.2	11	45	41	0.9
5	YS-5/25	N11100002	50	25	7.2	18	97	42	1.0
5	YS-5/75	N11100003	50	75	7.2	53	157	42	1.5
5	YS-5/127	N11100004	50	127	7.2	90	214	42	2.0
5	YS-5/180	N11100005	50	180	7.2	127	267	42	2.4
10	YS-10/25	N11100006	100	25	14.3	37	90	57	1.6
10	YS-10/50	N11100007	100	50	14.3	73	125	57	2.1
10	YS-10/100	N11100008	100	100	14.3	146	178	57	2.8
10	YS-10/150	N11100009	100	150	14.3	218	250	57	4.1
10	YS-10/200	N11100010	100	200	14.3	291	300	57	4.7
10	YS-10/250	N11100011	100	250	14.3	363	352	57	5.5
10	YS-10/300	N11100012	100	300	14.3	436	407	57	6.3
15	YS-15/25	N11100013	150	25	21.5	53	110	67	2.7
15	YS-15/50	N11100014	150	50	21.5	106	140	67	3.3
15	YS-15/100	N11100015	150	100	21.5	213	190	67	4.3
15	YS-15/150	N11100016	150	150	21.5	319	260	67	5.8
15	YS-15/200	N11100017	150	200	21.5	425	310	67	7.0
15	YS-15/250	N11100018	150	250	21.5	531	365	67	8.0
15	YS-15/300	N11100019	150	300	21.5	637	420	67	9.0
15	YS-15/350	N11100020	150	350	21.5	744	472	67	10.0
23	YS-23/25	N11100021	230	25	32.9	83	116	85	5.0
23	YS-23/50	N11100022	230	50	32.9	166	150	85	6.0
23	YS-23/100	N11100023	230	100	32.9	332	202	85	7.5
23	YS-23/160	N11100024	230	160	32.9	531	277	85	10.0
23	YS-23/210	N11100025	230	210	32.9	697	330	85	12.0
23	YS-23/250	N11100026	230	250	32.9	830	376	85	13.5
23	YS-23/300	N11100027	230	300	32.9	996	428	85	15.0
23	YS-23/345	N11100028	230	345	32.9	1145	477	85	16.5
30	YS-30/125	N11100029	300	125	42.9	552	245	102	13.0
30	YS-30/200	N11100030	300	200	42.9	884	325	102	17.0
50	YS-50/50	N11100031	500	50	71.5	355	170	125	15.0
50	YS-50/100	N11100032	500	100	71.5	709	220	125	19.0
50	YS-50/160	N11100033	500	160	71.5	1135	285	125	24.0
50	YS-50/320	N11100034	500	320	71.5	2269	460	125	37.0
70	YS-70/150	N11100035	700	150	100.0	1478	285	146	32.0
70	YS-70/330	N11100036	700	330	100.0	3252	490	146	52.0
100	YS-100/100	N11100476	1000	100	143.0	1432	275	180	43.0
100	YS-100/200	N11100037	1000	200	143.0	2863	375	180	64.0



Accessories for YS cylinders like lifting claws, piston plates, base adaptors, extension tubes, support plates and threaded flanges are also available



Support plates are available as accessories



Threaded flanges are available as accessories

**INFO**

For accessories for cylinders series YS please see pages 380 - 382.



## Dimensions YS

Model	YS-5/15	YS-5/25	YS-5/75	YS-5/127	YS-5/180	YS-10/25	YS-10/50	YS-10/100	YS-10/150	YS-10/200
A, mm	45	97	157	214	267	90	125	178	250	300
B, mm	60	122	232	341	447	115	175	278	400	500
C, mm	45	92	152	209	262	88	119	172	244	294
D, mm	41	42	42	42	42	57	57	57	57	57
E, mm	30	30	30	30	30	43	43	43	43	43
F, mm	25	26	26	26	26	38	38	38	38	38
H, mm	19	19	19	19	19	17	19	19	21	21
J, mm	–	25	25	25	25	–	35	35	35	35
K, mm	–	5	5	5	5	3	6	6	6	6
O, mm	–	M20 x 2	M20 x 2	M20 x 2	M20 x 2	–	M27 x 2	M27 x 2	M27 x 2	M27 x 2
P, mm	–	13	13	13	13	–	17	17	22	22
S, mm	–	–	–	–	–	–	–	–	–	–
U, mm	28.5	28	28	28	28	35	35	35	35	35
V, mm	2 x 5.5 Ø	2 x M6	2 x M6	2 x M6	2 x M6	2 x M8	2 x M8	2 x M8	2 x M8	2 x M8
W, mm	–	23	23	23	23	27	27	27	27	27
X, mm	–	M42 x 1.5	M42 x 1.5	M42 x 1.5	M42 x 1.5	M57 x 1.5	M57 x 1.5	M57 x 1.5	M57 x 1.5	M57 x 1.5
Z, °	5	5	5	5	5	5	5	5	–	–

Model	YS-10/250	YS-10/300	YS-15/25	YS-15/50	YS-15/100	YS-15/150	YS-15/200	YS-15/250	YS-15/300	YS-15/350
A, mm	352	407	110	140	190	260	310	365	420	472
B, mm	602	707	135	190	290	410	510	615	720	822
C, mm	346	401	103	133	183	253	303	358	413	465
D, mm	57	57	67	67	67	67	67	67	67	67
E, mm	43	43	52	52	52	52	52	52	52	52
F, mm	38	38	46	46	46	46	46	46	46	46
H, mm	21	21	19	19	19	22	22	22	22	22
J, mm	35	35	40	40	40	40	40	40	40	40
K, mm	6	6	7	7	7	7	7	7	7	7
O, mm	M27 x 2	M27 x 2	M33 x 2	M33 x 2	M33 x 2	M33 x 2	M33 x 2	M33 x 2	M33 x 2	M33 x 2
P, mm	22	22	19	19	19	25	25	25	25	25
S, mm	–	–	–	–	–	–	–	–	–	–
U, mm	35	35	42	42	42	42	42	42	42	42
V, mm	2 x M8	2 x M8	2 x M10	2 x M10	2 x M10	2 x M10	2 x M10	2 x M10	2 x M10	2 x M10
W, mm	27	27	33	33	33	33	33	33	33	33
X, mm	M57 x 1.5	M57 x 1.5	M67 x 1.5	M67 x 1.5	M67 x 1.5	M67 x 1.5	M67 x 1.5	M67 x 1.5	M67 x 1.5	M67 x 1.5
Z, °	–	–	5	5	5	–	–	–	–	–

Model	YS-23/25	YS-23/50	YS-23/100	YS-23/160	YS-23/210	YS-23/250	YS-23/300	YS-23/345	YS-30/125	YS-30/200
A, mm	116	150	202	277	330	376	428	477	245	325
B, mm	141	200	302	437	540	626	728	822	370	525
C, mm	113	142	194	269	322	368	420	469	235	315
D, mm	85	85	85	85	85	85	85	85	102	102
E, mm	65	65	65	65	65	65	65	65	75	75
F, mm	56	56	56	56	56	56	56	56	65	65
H, mm	20	22	22	22	22	22	22	22	25	25
J, mm	50	50	50	50	50	50	50	50	50	50
K, mm	3	8	8	8	8	8	8	8	10	10
O, mm	M40 x 2	M40 x 2	M40 x 2	M40 x 2	M40 x 2	M40 x 2	M40 x 2	M40 x 2	M36 x 2	M36 x 2
P, mm	15	22	22	25	25	25	25	25	25	25
S, mm	–	–	–	–	–	–	–	–	–	–
U, mm	55	55	55	55	55	55	55	55	75	75
V, mm	4 x M10	4 x M10	4 x M10	4 x M10	4 x M10	4 x M10	4 x M10	4 x M10	4 x M10	4 x M10
W, mm	40	40	40	40	40	40	40	40	45	45
X, mm	M85 x 2	M85 x 2	M85 x 2	M85 x 2	M85 x 2	M85 x 2	M85 x 2	M85 x 2	M102 x 2	M102 x 2
Z, °	5	–	–	–	–	–	–	–	–	–

**Dimensions YS**

Model	YS-50/50	YS-50/100	YS-50/160	YS-50/320	YS-70/150	YS-70/330	YS-100/100	YS-100/200
A, mm	170	220	285	460	285	490	275	375
B, mm	220	320	445	780	435	820	375	575
C, mm	165	215	280	455	280	485	270	370
D, mm	125	125	125	125	146	146	180	180
E, mm	95	95	95	95	112	112	135	135
F, mm	85	85	85	85	95	95	115	115
H, mm	29	29	29	29	30	30	60	60
J, mm	70	70	70	70	80	80	100	100
K, mm	5	5	5	5	5	5	5	5
O, mm	4 x M8	4 x M8	4 x M8	4 x M8	4 x M8	4 x M8	4 x M10	4 x M10
P, mm	-	-	-	-	-	-	-	-
S, mm	-	51	51	24	24	24	24	24
U, mm	95	95	95	95	110	110	145	145
V, mm	4 x M12	4 x M12	4 x M12	4 x M12	4 x M12	4 x M12	4 x M12	4 x M12
W, mm	50	50	50	50	60	60	70	70
X, mm	M125 x 2	M125 x 2	M125 x 2	M125 x 2	M146 x 3	M146 x 3	M180 x 3	M180 x 3
Z, °	-	-	-	-	-	-	-	-

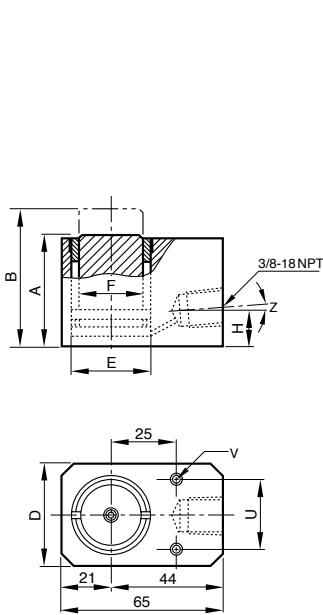

YS-5/15

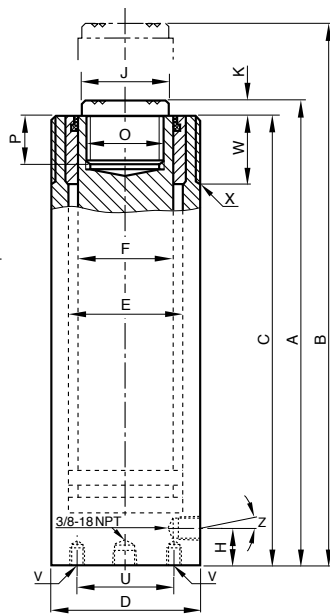

YS-5/25 up to YS-30/200

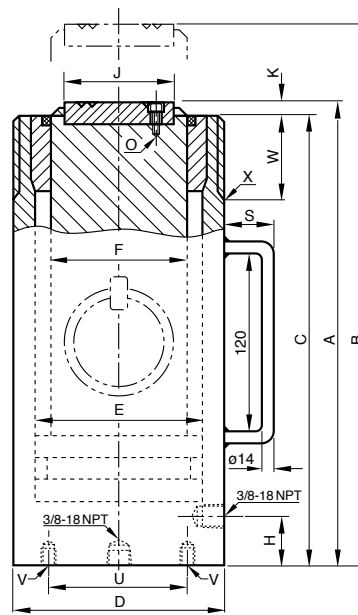

YS-50/50 up to YS-100/200

**INFO**

Subject to changes.



YLS



YFS

## YLS and YFS Low-height and flat cylinders

**Single-acting with spring return,  
capacity max. 10 - 100 t**

Low-height cylinders are recommended for all lifting, pushing, levelling, pressing applications especially in tight working areas.

These very compact hydraulic cylinders are designed for lifting and positioning jobs as well as all general maintenance applications, where low height, portability and light weight are needed. These versatile cylinders are found in all industrial areas like steel mills, civil engineering, heavy construction industry, power plants, off-shore industries etc. Due to their short strokes flat cylinders should not be subjected to side loading.

### Features

- Yale Chromo-Design.
- Operating pressure max. 700 bar.
- Single-acting with spring return.
- Low height for tight working areas.
- Cylinder body and piston are made from solid chromium-molybdenum steel and heat-treated.
- Stop ring can bear full capacity (pressure) and is fitted with dirt wiper. Dirt wiper protects against dirt.
- Oil port thread 3/8 NPT.
- Incl. female coupler half CFY-1.
- YLS-100/55 with lifting rings,  
YFS-100/15 with carrying handle.

## INFO

Selection charts "cylinder/hand pumps" can be found on pages 438 - 439.

Travel-speed charts are supplied on pages 440 - 441.



Technical data YLS

Cylinder size	Model	Art.-No.	Capacity max.	Stroke	Effective plunger area	Oil volume max.	Closed height	Cylinder outside diameter	Weight
t			kN	mm	cm <sup>2</sup>	cm <sup>3</sup>	mm	mm	kg
10	YLS-10/35	N11300634	100	35	14.3	51	86	70	2.5
20	YLS-20/45	N11300635	200	45	28.6	128	100	85	4.0
30	YLS-30/60	N11300636	300	60	42.9	266	120	100	6.5
50	YLS-50/60	N11300637	500	60	71.5	426	122	125	10.4
100	YLS-100/55	N11300638	1000	55	143.0	788	141	170	24.0

Technical data YFS

Cylinder size	Model	Art.-No.	Capacity max.	Stroke	Effective plunger area	Oil volume max.	Closed height	Cylinder outside diameter	Weight
t			kN	mm	cm <sup>2</sup>	cm <sup>3</sup>	mm	mm	kg
10	YFS-10/11	N11300629	100	11	14.3	16	43	56	1.5
20	YFS-20/15	N11300630	200	15	28.6	31	60	76	3.0
30	YFS-30/15	N11300631	300	15	44.2	66	60	96	4.2
50	YFS-50/15	N11300632	500	15	71.5	107	70	145	8.7
100	YFS-100/15	N11300633	1000	15	143.0	215	91	170	16.0

Dimensions YLS and YFS

Model	YLS-10/35	YLS-20/45	YLS-30/60	YLS-50/60	YLS-100/55	YFS-10/11	YFS-20/15	YFS-30/15	YFS-50/15	YFS-100/15
A, mm	86	100	120	122	141	43	60	60	70	91
B, mm	121	145	180	182	196	54	75	75	85	106
D, mm	70	85	100	125	170	56	76	96	145	170
D1, mm	-	-	-	-	-	83	95	115	-	-
E, mm	43	60	75	95	135	43	60	75	95	135
F, mm	38	50	57	75	120	38	50	57	75	120
H, mm	16	17	19	19	26	16	19	19	19	22
M, mm	-	-	-	-	148	-	-	-	-	85
Q, mm	-	-	-	-	-	28	38	48	-	-
R, mm	54	54	54	54	54	54	54	54	54	54
S, mm	-	-	-	-	25	-	-	-	-	55
Z, °	10	10	5	5	-	10	5	5	5	5

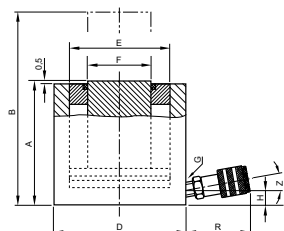

YLS

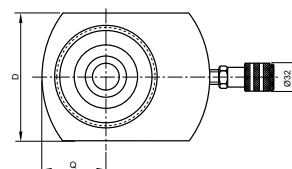
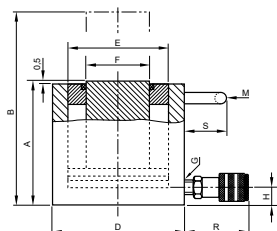

YFS

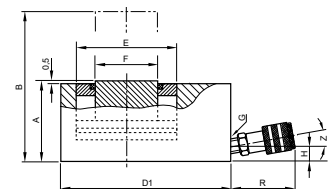



## YPL Pull cylinder

### Single-acting with spring return, capacity max. 10 - 51 t

Pull cylinders are able to produce extremely high pulling forces and can be controlled precisely by the use of hand pumps or power packs. In neutral position pull cylinders are fully extended. As soon as the cylinders are pressurized the forged links are drawn together. A built-in return spring extends the piston again as soon as the pressure is released.

Shipbuilding, heavy-vessel construction, steel construction, civil engineering as well as general repair and maintenance applications.

### Features

- Yale ChroMo-Design.
- Operating pressure max. 700 bar.
- Single-acting with spring return.
- Can be operated in all positions (except model YPPS).
- Cylinder body and piston are made from solid chromium-molybdenum steel and heat-treated.
- Hard-chromium plated piston with replaceable, heat-treated saddle.
- Stop ring can bear full capacity (pressure) and is fitted with dirt wiper. Dirt wiper protects against dirt.
- Forged, replaceable links.
- With carrying handle and piston protection cover.
- Oil port thread 3/8 NPT.
- Incl. female coupler half CFY-1.
- The pull cylinder YPPS-10/150 is equipped with an integrated hand pump similar to HPS-2/0,7A.

## INFO

Selection charts "cylinder/hand pumps" can be found on pages 438 - 439.

Travel-speed charts are supplied on pages 440 - 441.

**Technical data YPL**

Cylinder size	Model	Art.-No.	Capacity max.	Stroke	Effective plunger area	Oil volume max.	Length between links	Weight
t			kN	mm	cm <sup>2</sup>	cm <sup>3</sup>	mm	kg
10	YPL-10/150	N11900349	100	150	14.2	213	750	9
20	YPL-20/150	N11900350	200	150	30.6	459	795	22
30	YPL-30/150	N11900351	300	150	42.6	639	875	29
51	YPL-51/150	N11900927	510	150	74.6	1120	955	59
10	YPPS-10/150	N11900001	100	150	14.2	213	750	19

**Dimensions YPL**

Model	YPL-10/150	YPL-20/150	YPL-30/150	YPL-51/150	YPPS-10/150
A, mm	749	795	875	955	749
B, mm	78	95	120	150	78
C, mm	32	35	56	70	32
D, mm	68	105	121	156	68
E, mm	120	120	150	150	120
G, mm	23	30	32	40	23
H, mm	M24 x 1.5	M45 x 2	M50 x 2	M60 x 2	M24 x 1.5

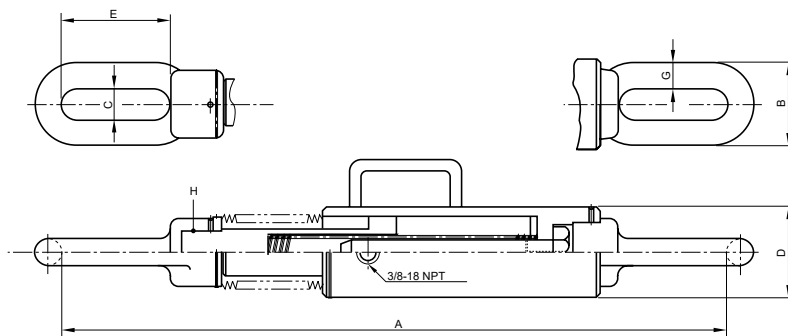



## INFO

Selection charts "cylinder/hand pumps" can be found on pages 438-439.

Travel-speed charts are supplied on pages 440-441.

## YCS Hollow cylinders

### Single-acting with spring return, capacity 12 - 93 t

Due to the centre hole design a threaded rod can be placed through the hollow cylinders so that extremely high pulling forces can be achieved.

Hollow cylinders are used as the power component within hydraulic puller sets, for prestressing anker bolts, removing axles, shafts, bushings, extracting tubes, as well as for heavy-duty pulling applications.

### Features

- Yale Chromo-Design.
- Operating pressure max. 700 bar.
- Single-acting with spring return.
- With large centre hole diameter.
- Cylinder body and piston are made from solid chromium-molybdenum steel and heat-treated.
- Hard-chromium plated piston with replaceable, heat-treated saddle.
- Metric mounting threads at cylinder body and inside of piston.
- Stop ring prevents overtravel of the piston up to full operating pressure.
- Interchangeable hardened saddle.
- With inner and outer dirt wipers.
- Oil port thread 3/8 NPT.
- Incl. female coupler half CFY-1.
- From YCS-21/150 with carrying handle.
- From YCS-57/70 with two lifting rings.



## Function principal of the hollow cylinders

In connection with threaded rods hollow cylinders can produce extremely high forces which are helpful for various repair or assembly applications like removing press-fitted parts, prestressing anchors etc.

In addition, hollow cylinders are used as power source in puller sets and test rigs. By the use of long threaded rods and by readjusting the nut larger distances can be pulled even when using short cylinder strokes.

**Technical data YCS**

Cylinder size	Model	Art.-No.	Capacity	Stroke	Effective plunger area	Oil volume max.	Closed height	Centre hole diameter	Cylinder outside diameter	Weight
t			kN	mm	cm <sup>2</sup>	cm <sup>3</sup>	mm	mm	mm	kg
12	YCS-12/40	N11400070	120	40	17.2	71	142	20	70	3.5
12	YCS-12/75	N11400071	120	75	17.2	132	195	20	70	4.5
21	YCS-21/50	N11400072	214	50	30.5	153	173	27	100	8.5
21	YCS-21/150	N11400073	214	150	30.5	458	335	27	100	15.0
33	YCS-33/60	N11400074	335	60	47.9	287	193	33	114	12.0
33	YCS-33/150	N11400075	335	150	47.9	716	343	33	114	21.0
57	YCS-57/70	N11400076	567	70	81.0	562	242	42	150	25.0
62	YCS-62/150	N11400077	618	150	88.3	1330	335	55	163	38.0
93	YCS-93/75	N11400078	930	75	133	990	280	80	214	55.0

**Dimensions YCS**

Model	YCS-12/40	YCS-12/75	YCS-21/50	YCS-21/150	YCS-33/60	YCS-33/150	YCS-57/70	YCS-62/150	YCS-93/75
A, mm	135	188	163	325	183	333	230	323	265
B, mm	175	263	213	475	243	483	300	473	340
C, mm	20	20	27	27	33	33	42	55	80
D, mm	70	70	100	100	114	114	150	163	214
E, mm	55	55	73	73	90	90	118	130	170
F, mm	40	40	53	53	65	65	90	100	136
J, mm	38	38	50	50	62	62	85	96	132
K, mm	3	3	3	3	3	3	3	3	5
M, mm	-	-	-	120	-	120	-	-	-
O, mm	M30 x 1.5	M30 x 1.5	M40 x 1.5	M40 x 1.5	M48 x 1.5	M48 x 1.5	M65 x 2	M78 x 2	M115 x 2
P, mm	20	20	25	25	30	30	35	40	45
R, mm	4	4	5	5	5	5	5	5	-
S, mm	-	-	-	51	-	51	24	24	24
T, mm	-	-	-	-	-	-	155	200	170
U, mm	58	58	82	82	92	92	120	135	180
V, mm	2 x M8	2 x M8	2 x M10	2 x M10	4 x M10	4 x M10	4 x M12	4 x M12	4 x M16
W, mm	30	30	35	35	40	40	50	60	-
X, mm	M70 x 2	M70 x 2	M100 x 2	M100 x 2	M110 x 2	M110 x 2	M150 x 3	M160 x 3	-
Y, mm	7	7	10	10	10	10	12	12	15

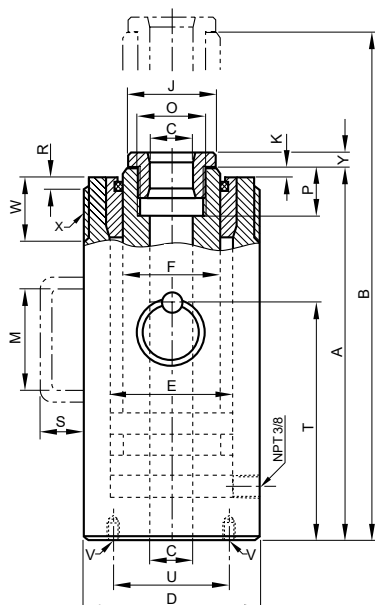



## YCH Hollow cylinders

### Double-acting with hydraulic return, capacity 33 - 140 t

Basically, the applications are the same as for the single-acting hollow cylinders shown on the opposite page, but for this model range the return of the piston is done hydraulically by means of the second oil port. These double-acting hollow cylinders are used when the piston needs to be retracted quickly e.g. with high-cycle pulling applications.

#### Features

- Yale ChroMo-Design.
- Operating pressure max. 700 bar.
- Double-acting with hydraulic return.
- With large centre hole diameter.
- Cylinder body and piston are made from solid chromium-molybdenum steel and heat-treated.
- Hard-chromium plated piston with replaceable, heat-treated saddle.
- Metric mounting threads at cylinder body and inside of piston.
- Stop ring prevents overtravel of the piston up to full operating pressure.
- Interchangeable hardened saddle.
- With inner and outer dirt wipers.
- Oil port thread 3/8 NPT.
- Incl. 2 female coupler halves CFY-1.
- All cylinders with carrying handle, from model YCH-62/250 with 2 lifting rings.



## INFO

On request we supply special hollow cylinders with pulling capacities up to 600 tons.

Selection charts "cylinder/hand pumps" can be found on pages 438 - 439.

Travel-speed charts are supplied on pages 440 - 441.

## Technical data YCH

Cylinder size	Model	Art.-No.	Capacity push	Capacity pull	Stroke	Effective plunger area	Oil volume max.	Closed height	Centre hole diameter	Cylinder outside diameter	Weight
t			kN	kN	mm	cm <sup>2</sup>	cm <sup>3</sup>	mm	mm	mm	kg
33	<b>YCH-33/150</b>	N11400079	335	180	150	47.9	716	310	33	114	19
33	<b>YCH-33/250</b>	N11400080	335	180	250	47.9	1200	415	33	114	25
62	<b>YCH-62/250</b>	N11400081	618	300	250	88.3	2220	452	55	163	55
93	<b>YCH-93/250</b>	N11400082	930	450	250	133.0	3320	465	55	193	82
100	<b>YCH-100/40</b>	N11400083	1000	500	40	143.0	578	190	55	200	38
140	<b>YCH-140/200</b>	N11400084	1400	700	200	200.2	4080	383	80	253	115

For double-acting hollow cylinders the "capacity push" is equivalent to the max. pulling force achieved with tensioning anchor or threaded spindle.

## Dimensions YCH

Model	YCH-33/150	YCH-33/250	YCH-62/250	YCH-93/250	YCH-100/40	YCH-140/200
A, mm	300	405	440	450	175	365
B, mm	450	655	690	700	215	565
C, mm	33	33	55	55	55	80
D, mm	114	114	163	193	200	253
E, mm	90	90	130	150	155	195
F, mm	67	67	105	120	125	160
J, mm	62	62	96	110	110	145
K, mm	3	3	5	5	5	5
M, mm	120	120	-	-	-	-
O, mm	M48 x 1,5	M48 x 1,5	M78 x 2	M85 x 2	M85 x 2	M115 x 2
P, mm	30	30	40	45	45	50
R, mm	5	5	5	5	-	-
S, mm	51	51	24	30	24	30
T, mm	-	-	290	290	115	240
U, mm	92	92	135	160	165	210
V, mm	4 x M10	4 x M10	4 x M12	4 x M16	4 x M16	4 x M16
W, mm	40	40	50	65	-	-
X, mm	M110 x 2	M110 x 2	M160 x 3	M190 x 3	-	-
Y, mm	10	10	12	15	15	18

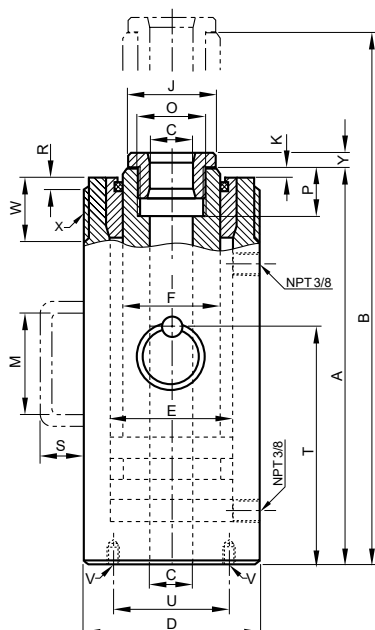



## YH Universal cylinders

### Double-acting with hydraulic return, capacity 5 - 200 t

These extremely robust double-acting cylinders are especially designed for universal heavy-duty lifting and positioning applications as well as for industrial production and assembly jobs. The cylinders offer high pushing and pulling forces. The double-acting design assures a high piston retraction speed.

Major areas of application are bridge building and civil engineering, off-shore, ship building, etc. They can also be used as power source in frame presses, stamping fixtures and other industrial uses where high pushing and pulling forces are required.

#### Features

- Yale ChroMo-Design.
- Operating pressure max. 700 bar.
- Double-acting with hydraulic return.
- Long bronze piston guidings.
- Piston strokes from 30 up to 500 mm.
- Cylinder body and piston are made from solid chromium-molybdenum steel and heat-treated.
- Hard-chromium plated piston with replaceable, heat-treated saddle.
- Metric mounting threads on cylinder housing, in the bottom of the cylinder body and in the piston rod.
- Stop ring can bear full capacity (pressure) and is fitted with dirt wiper.
- Interchangeable hardened saddle.
- Dirt wiper protects against dirt.
- Oil port thread 3/8 NPT.
- Incl. 2 female coupler halves CFY-1.
- From YH-30/200 with carrying handle.
- From YH-50/350 with 2 lifting rings.

## INFO

For cylinders series YH accessories please see pages 382 - 383.

Selection charts "cylinder/hand pumps" can be found on pages 438 - 439.

Travel-speed charts are supplied on pages 440 - 441.

## Technical data YH

Cylinder size	Model	Art.-No.	Capacity push	Capacity pull	Stroke	Effective plunger area push	Effective plunger area pull	Oil volume max.	Closed height	Cylinder outside diameter	Weight
t			kN	kN	mm	cm <sup>2</sup>	cm <sup>2</sup>	cm <sup>3</sup>	mm	mm	kg
5	YH-5/30	N11200038	50	22	30	7.2	3.1	21	160	55	2.5
5	YH-5/80	N11200039	50	22	80	7.2	3.1	57	210	55	3.3
5	YH-5/150	N11200040	50	22	150	7.2	3.1	106	280	55	4.4
10	YH-10/30	N11200041	100	45	30	14.3	6.4	44	175	67	4.0
10	YH-10/80	N11200042	100	45	80	14.3	6.4	116	225	67	5.0
10	YH-10/150	N11200043	100	45	150	14.3	6.4	218	295	67	6.7
10	YH-10/250	N11200044	100	45	250	14.3	6.4	363	395	67	9.0
20	YH-20/50	N11200045	200	100	50	28.6	14.3	142	195	85	7.0
20	YH-20/150	N11200046	200	100	150	28.6	14.3	424	310	85	11.0
20	YH-20/250	N11200047	200	100	250	28.6	14.3	707	410	85	14.0
30	YH-30/200	N11200048	300	140	200	42.9	20.0	884	355	102	19.0
30	YH-30/350	N11200049	300	140	350	42.9	20.0	1547	510	102	27.0
50	YH-50/150	N11200050	500	220	150	71.5	31.5	1064	325	125	27.0
50	YH-50/350	N11200051	500	220	350	71.5	31.5	2481	525	125	42.0
50	YH-50/500	N11200052	500	220	500	71.5	31.5	3544	685	125	52.0
70	YH-70/150	N11200053	700	330	150	100.0	47.2	1478	335	146	37.0
70	YH-70/350	N11200054	700	330	350	100.0	47.2	3449	540	146	56.0
100	YH-100/50	N11200055	1000	450	50	143.0	64.4	716	265	180	49.0
100	YH-100/150	N11200056	1000	450	150	143.0	64.4	2148	365	180	64.0
100	YH-100/350	N11200057	1000	450	350	143.0	64.4	5010	565	180	94.0
100	YH-100/500	N11200058	1000	450	500	143.0	64.4	7157	725	180	118.0
200	YH-200/150	N11200059	2000	900	150	286.0	128.7	4253	410	250	137.0
200	YH-200/350	N11200060	2000	900	350	286.0	128.7	9924	620	250	198.0
200	YH-200/500	N11200061	2000	900	500	286.0	128.7	14177	780	250	244.0



# Hydraulic Jacks & Tools    Hydraulic cylinders, double-acting

## Dimensions YH

Model	YH-5/30	YH-5/80	YH-5/150	YH-10/30	YH-10/80	YH-10/150	YH-10/250	YH-20/50	YH-20/150	YH-20/250	YH-30/200	YH-30/350
A, mm	160	210	280	175	225	295	395	195	310	410	355	510
B, mm	190	290	430	205	305	445	645	245	460	660	555	860
C, mm	138	188	258	150	200	270	370	167	282	382	345	500
D, mm	55	55	55	67	67	67	67	85	85	85	102	102
E, mm	30	30	30	43	43	43	43	60	60	60	75	75
F, mm	22.4	22.4	22.4	32	32	32	32	42	42	42	55	55
H, mm	31	31	31	35	35	35	35	22	37	37	46	46
I, mm	44	44	44	50	50	50	50	59	59	59	64	64
J, mm	-	-	-	-	-	-	-	-	-	-	50	50
K, mm	4	4	4	5	5	5	5	5	5	5	10	10
L, mm	17	17	17	20	20	20	20	-	22	22	28	28
O, mm	M18 x 1.5	M18 x 1.5	M18 x 1.5	M27 x 2	M27 x 2	M27 x 2	M27 x 2	M36 x 2	M36 x 2	M36 x 2	M36 x 2	M36 x 2
P, mm	18	18	18	20	20	20	20	23	23	23	28	28
S, mm	-	-	-	-	-	-	-	-	-	-	51	51
U, mm	-	-	-	-	-	-	-	-	-	-	-	-
V, mm	M27 x 2	M27 x 2	M27 x 2	M36 x 2	M36 x 2	M36 x 2	M36 x 2	-	M45 x 2	M45 x 2	M36 x 2	M36 x 2
W, mm	27	27	27	33	33	33	33	40	40	40	45	45
X, mm	M55 x 1.5	M55 x 1.5	M55 x 1.5	M67 x 1.5	M67 x 1.5	M67 x 1.5	M67 x 1.5	M85 x 2	M85 x 2	M85 x 2	M102 x 2	M102 x 2

Model	YH-50/150	YH-50/350	YH-50/500	YH-70/150	YH-70/350	YH-100/50	YH-100/150	YH-100/350	YH-100/500	YH-200/150	YH-200/350	YH-200/500
A, mm	325	525	685	335	540	265	365	565	725	410	620	780
B, mm	475	875	1.185	485	890	315	515	915	1.225	560	970	1.280
C, mm	313	513	673	321	526	250	350	550	710	391	601	761
D, mm	125	125	125	146	146	180	180	180	180	250	250	250
E, mm	95	95	95	112	112	135	135	135	135	190	190	190
F, mm	70	70	70	80	80	100	100	100	100	140	140	140
H, mm	55	55	55	58	58	66	66	66	66	80	80	80
I, mm	70	70	70	79	79	90	90	90	95	105	105	105
J, mm	65	65	65	75	75	90	90	90	90	127	127	127
K, mm	12	12	12	14	14	15	15	15	15	19	19	19
L, mm	31	31	31	35	35	-	-	-	-	-	-	-
O, mm	M45 x 2	M45 x 2	M45 x 2	M50 x 3	M50 x 3	M65 x 3	M65 x 3	M65 x 3	M65 x 3	M90 x 3	M90 x 3	M90 x 3
P, mm	31	31	31	35	35	40	40	40	40	55	55	55
S, mm	51	24	24	24	24	24	24	30	30	30	30	30
U, mm	-	-	-	-	-	110	110	110	110	160	160	160
V, mm	M45 x 2	M45 x 2	M45 x 2	M50 x 3	M50 x 3	4 x M12	4 x M12	4 x M12	4 x M12	4 x M16	4 x M16	4 x M16
W, mm	50	50	50	60	60	70	70	70	70	80	80	80
X, mm	M125 x 2	M125 x 2	M125 x 2	M146 x 3	M146 x 3	M180 x 3	M180 x 3	M180 x 3	M180 x 3	M250 x 4	M250 x 4	M250 x 4

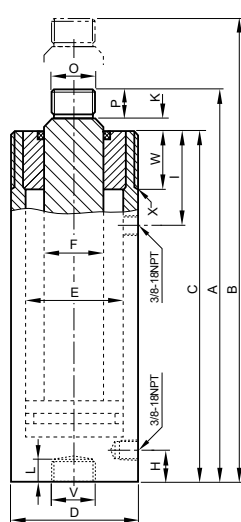

YH-5/30 up to YH 20/250

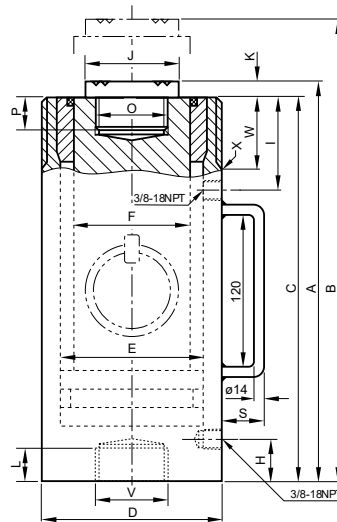

YH-30/200 up to YH 70/350

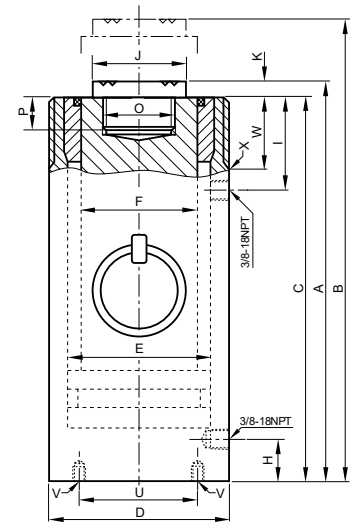

YH-100/50 up to YH 200/500





### YEHB High-tonnage cylinders

**Double-acting with hydraulic return,  
capacity max. 140 - 1100 t**

Cylinders of series YEHB are normally used for lifting, positioning or handling heavy loads. The double-acting function allows a faster piston return, even with longer hydraulic hoses.

Lifting and moving of large machinery, steel construction, bridges or similar loads, supporting of buildings and foundations.

Further applications are positioning, weighing, through pressing, stress testing or jacking of all kinds of loads.

#### Features

- Operating pressure max. 700 bar.
- Double-acting with hydraulic return.
- Generous guiding bands ensure a robust piston guiding.
- Hard chromium-plated piston.
- Stop ring as piston end stop.
- Interchangeable hardened saddle.
- Dirt wiper protects against dirt.
- Oil port thread 3/8 NPT.
- Incl. 2 female coupler halves CFY-1.
- Mounting threads on request.
- All cylinders have lifting rings.



### INFO

Selection charts "cylinder/hand pumps" can be found on pages 438 - 439.

Travel-speed charts are supplied on pages 440 - 441.

**Technical data YEHB**

Cylinder size	Model	Art.-No.	Capacity max.	Stroke	Effective plunger area	Oil volume max.	Closed height	Cylinder outside diameter	Weight
t			kN	mm	cm <sup>2</sup>	cm <sup>3</sup>	mm	mm	kg
140	YEHB-140/50	–	1407	50	201	1005	213	210	53
140	YEHB-140/150	–	1407	150	201	3016	318	210	74
140	YEHB-140/300	–	1407	300	201	6032	478	210	104
220	YEHB-220/50	–	2199	50	314	1571	233	260	90
220	YEHB-220/150	–	2199	150	314	4712	333	260	120
220	YEHB-220/300	–	2199	300	314	9425	498	260	169
310	YEHB-310/50	–	3036	50	434	2169	251	305	137
310	YEHB-310/150	–	3036	150	434	6506	357	305	189
310	YEHB-310/300	–	3036	300	434	13012	512	305	263
410	YEHB-410/50	–	4008	50	573	2863	275	350	197
410	YEHB-410/150	–	4008	150	573	8588	382	350	262
410	YEHB-410/300	–	4008	300	573	17177	538	350	357
520	YEHB-520/50	–	5114	50	731	3653	305	400	197
520	YEHB-520/150	–	5114	150	731	10959	410	400	262
520	YEHB-520/300	–	5114	300	731	21918	566	400	357
610	YEHB-610/50	–	5987	50	855	4276	315	430	342
610	YEHB-610/150	–	5987	150	855	12829	420	430	440
610	YEHB-610/300	–	5987	300	855	25659	576	430	583
830	YEHB-830/50	–	8149	50	1164	5821	335	505	504
830	YEHB-830/150	–	8149	150	1164	17462	446	505	649
830	YEHB-830/300	–	8149	300	1164	34925	606	505	858
1100	YEHB-1100/50	–	10644	50	1521	7603	365	570	696
1100	YEHB-1100/150	–	10644	150	1521	22808	476	570	869
1100	YEHB-1100/300	–	10644	300	1521	45616	636	570	1116



**INFO**

For tilt saddles for cylinders please see pages 378 - 379.





## YELB Hydraulic cylinders with safety lock nut

**Single-acting, gravity return  
capacity max. 30 - 1100 t**

Hydraulic cylinders with safety lock nut are recommended when loads have to remain in the lifted position over a period of time. The safety lock nut ensures a positive load hold in any position, and work can be carried out beneath the lifted load. Hydraulic pressure can be released so that cylinders work like mechanical supports. Pumps can be separated from cylinders.

Lifting and moving of large machinery, steel construction, bridges or similar loads, supporting of buildings and foundations.

For all heavy-duty jacking applications where a special safety factor is appropriate like lifting and lowering bridges, supporting buildings and foundations, jacking up heavy machines, steel sections, ship modules or similar loads.

### Features

- Operating pressure max. 700 bar.
- Single-acting, gravity return.
- Generous guiding bands ensure a robust piston guiding.
- Hard chromium-plated piston with trapezoidal thread.
- Overflow hole ensures a definite piston end stop.
- Interchangeable hardened saddle.
- Oil port thread 3/8 NPT.
- Incl. female coupler half CFY-1.
- All cylinders have lifting rings.

## INFO

Further piston strokes are quoted on request.

For tilt saddles for cylinders please see pages 378 - 379.



**Technical data YELB**

Cylinder size	Model	Art.-No.	Capacity max.	Stroke	Effective plunger area	Oil volume max.	Closed height	Cylinder outside diameter	Weight
t			kN	mm	cm <sup>2</sup>	cm <sup>3</sup>	mm	mm	kg
30	YELB-30/50	–	303	50	44	221	141	100	9
30	YELB-30/100	–	303	100	44	442	191	100	12
30	YELB-30/150	–	303	150	44	663	246	100	15
30	YELB-30/200	–	303	200	44	884	296	100	18
30	YELB-30/300	–	303	300	44	1325	405	100	25
50	YELB-50/50	–	496	50	71	354	153	125	14
50	YELB-50/100	–	496	100	71	709	203	125	19
50	YELB-50/150	–	496	150	71	1063	261	125	25
50	YELB-50/200	–	496	200	71	1418	311	125	30
50	YELB-50/300	–	496	300	71	2126	416	125	40
100	YELB-93/50	–	929	50	133	664	180	170	31
100	YELB-93/100	–	929	100	133	1327	230	170	40
100	YELB-93/150	–	929	150	133	1991	285	170	50
100	YELB-93/200	–	929	200	133	2655	335	170	59
100	YELB-93/300	–	929	300	133	3982	441	170	78
140	YELB-140/50	–	1407	50	201	1005	195	210	52
140	YELB-140/100	–	1407	100	201	2011	245	210	65
140	YELB-140/150	–	1407	150	201	3016	309	210	83
140	YELB-140/200	–	1407	200	201	4021	359	210	96
140	YELB-140/300	–	1407	300	201	6032	465	210	125
220	YELB-220/150	–	2192	150	314	4712	328	260	134
220	YELB-220/300	–	2192	300	314	9425	488	260	201
310	YELB-310/150	–	3037	150	434	6506	351	305	197
310	YELB-310/300	–	3037	300	434	13012	511	305	289
410	YELB-410/150	–	4008	150	573	8588	370	350	274
410	YELB-410/300	–	4008	300	573	17177	530	350	395
520	YELB-520/150	–	5114	150	731	10959	395	400	378
520	YELB-520/300	–	5114	300	731	21918	555	400	535
610	YELB-610/50	–	5987	50	855	4276	311	430	347
610	YELB-610/150	–	5987	150	855	12829	421	430	472
610	YELB-610/300	–	5987	300	855	25659	581	430	654
830	YELB-830/50	–	8149	50	1164	5821	348	505	537
830	YELB-830/150	–	8149	150	1164	17462	458	505	709
830	YELB-830/300	–	8149	300	1164	34925	618	505	959
1085	YELB-1100/50	–	10644	50	1520	7603	392	570	772
1085	YELB-1100/150	–	10644	150	1520	22808	502	570	991
1085	YELB-1100/300	–	10644	300	1520	45616	673	570	1332

**INFO**

Selection charts “cylinder/hand pumps” can be found on pages 438 - 439.

Travel-speed charts are supplied on pages 440 - 441.



## INFO

---

Further piston strokes are quoted on request.

The use of tilt saddles is recommended.

Selection charts "cylinder/hand pumps" can be found on pages 438 - 439.

Travel-speed charts are supplied on pages 440 - 441.

## YEGB High-tonnage cylinders

**Single-acting, gravity return  
capacity max. 140 - 1100 t**

These inexpensive cylinders of series YEGB are used for all general lifting applications in any area of industry where heavy loads need to be lifted, lowered, levelled, positioned or supported.

Lifting and moving large machinery, steel construction, bridges or similar loads, supporting buildings and foundations.

For all heavy-duty jacking applications where a special safety factor is appropriate like lifting and lowering bridges, supporting buildings and foundations, jacking up heavy machines, steel sections, ship modules or similar loads.

### Features

- Operating pressure max. 700 bar.
- Plunger in special piston guiding bands.
- Hard chromium-plated piston.
- Overflow hole ensures a definite piston end stop.
- Interchangeable hardened saddle.
- Oil port thread 3/8 NPT.
- Incl. female coupler half CFY-1.
- All cylinders have lifting rings.



## INFO

---

Available for all cylinder series YELB, YEGB and YEHB.

## AYB Tilt saddles for cylinders

Tilt saddles should be used with YELB and YEGB cylinders in cases where cylinders are operated on non-parallel surfaces.

The saddles minimize inner friction caused by eccentric loading of the cylinders. The upper part of the saddle can pivot up to 5° in all directions. Tilt saddles are fixed in the piston by means of an O-ring.

**Technical data YEGB**

Cylinder size t	Model	Art.-No.	Capacity max. kN	Stroke mm	Effective plunger area cm <sup>2</sup>	Oil volume max. cm <sup>3</sup>	Closed height mm	Cylinder outside diameter mm	Weight kg
140	YEGB-140/50	–	1407	50	201	1005	160	210	43
140	YEGB-140/150	–	1407	150	201	3016	274	210	74
140	YEGB-140/300	–	1407	300	201	6032	430	210	116
220	YEGB-220/50	–	2200	50	314	1571	180	260	75
220	YEGB-220/150	–	2200	150	314	4712	291	260	120
220	YEGB-220/300	–	2200	300	314	9425	451	260	187
310	YEGB-310/50	–	3036	50	434	2169	193	305	110
310	YEGB-310/150	–	3036	150	434	6506	309	305	176
310	YEGB-310/300	–	3036	300	434	13012	469	305	267
410	YEGB-410/50	–	4008	50	573	2863	215	350	161
410	YEGB-410/150	–	4008	150	573	8588	325	350	244
410	YEGB-410/300	–	4008	300	573	17177	485	350	364
520	YEGB-520/50	–	5114	50	731	3653	225	400	221
520	YEGB-520/150	–	5114	150	731	10959	335	400	329
520	YEGB-520/300	–	5114	300	731	21918	495	400	486
610	YEGB-610/50	–	5987	50	855	4276	236	430	268
610	YEGB-610/150	–	5987	150	855	12829	346	430	393
610	YEGB-610/300	–	5987	300	855	25659	506	430	574
830	YEGB-830/50	–	8149	50	1164	5821	263	505	411
830	YEGB-830/150	–	8149	150	1164	17462	373	505	583
830	YEGB-830/300	–	8149	300	1164	34925	533	505	834
1085	YEGB-1100/50	–	10644	50	1521	7603	292	570	582
1085	YEGB-1100/150	–	10644	150	1521	22808	402	570	801
1085	YEGB-1100/300	–	10644	300	1521	45616	573	570	1142

**Technical data AYB**

Model	Art.-No.	Suitable for cylinder groups	Weight kg
AYB-50	–	YELB-30 and YELB-50	0.4
AYB-93	–	YELB-93	0.8
AYB-140	–	YELB-140, YEGB-140, YEHB-140	2.0
AYB-220	–	YELB-220, YEGB-220, YEHB-220	3.4
AYB-310	–	YELB-310, YEGB-310, YEHB-310	13.0
AYB-410	–	YELB-410, YEGB-410, YEHB-410	on request
AYB-520	–	YELB-520, YEGB-520, YEHB-520	on request

Other sizes on request

**Dimensions AYB**

Model	AYB-50	AYB-93	AYB-140	AYB-220	AYB-310	AYB-410	AYB-520
L, mm	50	71.5	94	113	139	159	179
N, mm	34	30	39.2	43	68.5	78	77
O, mm	71	71	97	126	175	210	230

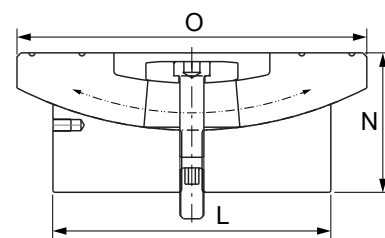



## AYS

### Lifting claws, piston plates, base adaptors and extension tubes, load-spreading plates

#### Lifting claws

In connection with the corresponding hydraulic cylinder a lifting claw represents a compact, lightweight and versatile lifting unit. The lifting claws are screwed onto the collar thread of cylinder series YS. Claws can be placed under loads with minimum clearance.

**When operating lifting claws, the following aspects have to be considered:**

The hydraulic cylinders need to be able to support themselves against the load. The max. force of the cylinder is reduced by 50%.

#### Piston plates

Piston plates can be screwed into the piston thread of cylinder series YS. They reduce the surface pressure and prevent the pistons from sinking into the ground. Also when using a piston plate in connection with a lifting claw the cylinder must be supported against the load.

#### Base adaptors and extension tubes

Extension tubes are mounted onto the bottom of cylinders series YS by means of the base adaptor and two hexagon socket screws (screws are included with the base adaptor). The use of extension tubes adds to the versatility of the standard cylinders.

#### Load-spreading plates

These load-spreading plates are recommended when slim cylinders are used for lifting operations. They prevent the cylinders from falling over and sinking into the ground. Robust steel design with carrying handle.



AYS-101  
151  
231



Straightening of a container box by use of a hydraulic cylinder YS-10/100, extension tube AYS-106, base adaptor AYS-103 and electric power pump PY-04/2/5/2 M.



Lifting of a container by use of an hydraulic cylinder YS-23/160, lifting claw AYS-23 and piston plate AYS-232 powered by a two-stage hand pump HPS-2/2 with base frame.

## Technical data AYS

Model	Art.-No.	Description	Suitable for cylinder	Weight kg
AYS-10	N14500303	Lifting claw, permissible capacity 5 t	YS-10/...	0.9
AYS-15	N14500304	Lifting claw, permissible capacity 8 t	YS-15/...	1.3
AYS-23	N14500311	Lifting claw, permissible capacity 12 t	YS-23/...	3.8
AYS-53	N14500672	Base adaptor, 5 t	YS-5/...	0.5
AYS-54	N14500673	Extension tube 125 mm, 5 t	YS-5/...	0.9
AYS-55	N14500674	Extension tube 250 mm, 5 t	YS-5/...	1.5
AYS-56	N14500675	Extension tube 500 mm, 5 t	YS-5/...	2.8
AYS-101	N14500678	Load-spreading plate 10 t	YS-10/...	10.5
AYS-102	N14500324	Piston plate, round	YS-10/...	1.5
AYS-103	N14500336	Base adaptor, 10 t	YS-10/...	0.7
AYS-104	N14500337	Extension tube 125 mm, 10 t	YS-10/...	1.2
AYS-105	N14500338	Extension tube 250 mm, 10 t	YS-10/...	2.2
AYS-106	N14500339	Extension tube 500 mm, 10 t	YS-10/...	3.9
AYS-107	N14500340	Extension tube 750 mm, 10 t	YS-10/...	5.9
AYS-151	N14500681	Load-spreading plate 15 t	YS-15/...	10.5
AYS-152	N14500325	Piston plate, round	YS-15/...	1.8
AYS-153	N14500506	Base adaptor, 15 t	YS-15/...	0.9
AYS-154	N14500507	Extension tube 125 mm, 15 t	YS-15/...	1.6
AYS-155	N14500508	Extension tube 250 mm, 15 t	YS-15/...	2.9
AYS-156	N14500509	Extension tube 500 mm, 15 t	YS-15/...	4.9
AYS-157	N14500510	Extension tube 750 mm, 15 t	YS-15/...	7.9
AYS-231	N14500684	Load-spreading plate 23 t	YS-23/...	10.5
AYS-232	N14500326	Piston plate, round	YS-23/...	2.2

## Dimensions AYS

Model	AYS-10	AYS-15	AYS-23	AYS-53	AYS-54	AYS-55	AYS-56	AYS-101	AYS-102	AYS-103	AYS-104	AYS-105
A, mm	90	110	125	53	125	250	500	230	140	58	125	250
B, mm	90	110	125	50	-	-	-	120	12	60	-	-
C, mm	30	30	30	-	-	-	-	58	-	-	-	-
D, mm	29	34	40	-	-	-	-	-	-	-	-	-
E, mm	22	25	35	-	-	-	-	-	-	-	-	-
F, mm	M57 x 1.5	M67 x 1.5	M85 x 2	M42 x 1.5	M42 x 1.5	M42 x 1.5	M42 x 1.5	-	M27 x 2	M50 x 2	M50 x 2	M50 x 2

Model	AYS-106	AYS-107	AYS-151	AYS-152	AYS-153	AYS-154	AYS-155	AYS-156	AYS-157	AYS-231	AYS-232
A, mm	500	750	230	140	70	125	250	500	750	230	160
B, mm	-	-	120	12	73	-	-	-	-	120	15
C, mm	-	-	68	-	-	-	-	-	-	86	-
D, mm	-	-	-	-	-	-	-	-	-	-	-
E, mm	-	-	-	-	-	-	-	-	-	-	-
F, mm	M50 x 2	M50 x 2	-	M33 x 2	M60 x 2	M60 x 2	M60 x 2	M60 x 2	M60 x 2	-	M40 x 2

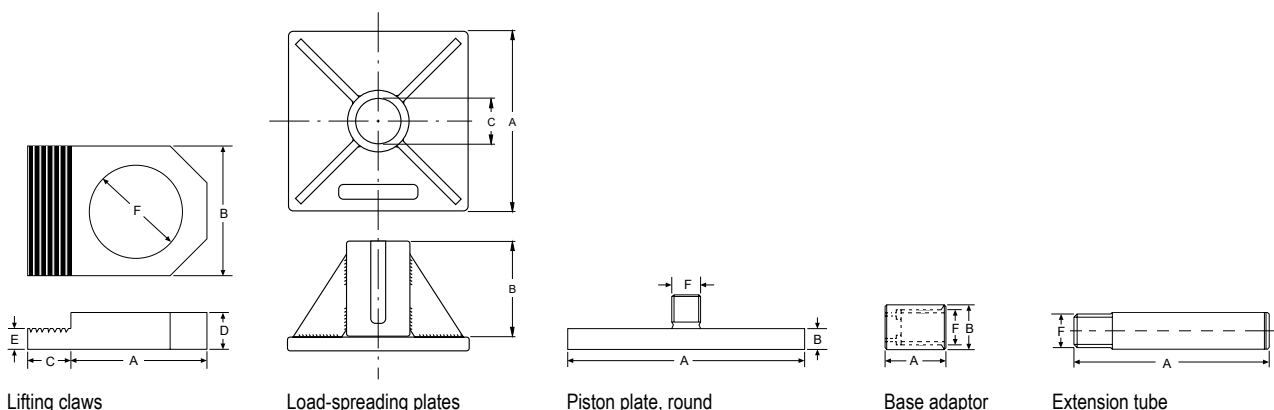



## AYP Threaded flanges

In case hydraulic cylinders have to be inserted into fixtures, press frames or similar devices, these steel flanges can be very handy. Material: weldable steel.

### Technical data AYP

Model	Art.-No.	Suitable for cylinder	Weight kg
AYP-1010	N13700670	YS-10/...	9.7
AYP-1510	N13700671	YS-15/... and YH-10/...	12.6
AYP-2310	N13700672	YS-23/... and YH-20/...	12.1
AYP-5010	N13701058	YS-50/... and YH-50/...	19.6
AYP-10010	N13701059	YS-100/... and YH-100/...	46.0

### Dimensions AYP

Model	AYP-1010	AYP-1510	AYP-2310	AYP-5010	AYP-10010
A, mm	M57 x 1.5	M67 x 1.5	M85 x 2	M125 x 2	M180 x 3
B, mm	220	220	220	250	330
C, mm	200	200	200	250	330
D, mm	30	40	40	50	70
E, mm	120	120	120	225	300
F, mm	150	150	150	225	300
G, mm	M12	M12	M12	Ø 13.5	Ø 17.5
H, mm	M8	M8	M8	M8	M8

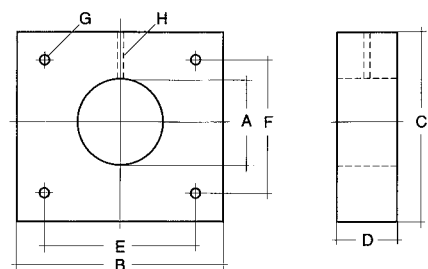

AYP

## AYH Clevis eye mountings

Clevis eye mountings are screwed onto the piston and bottom of the hydraulic cylinder whenever mounting conditions require a pivoting of the cylinder.



### Technical data AYH

Model	Art.-No.	Suitable for cylinder	Suitable for	Weight kg
AYH-5-1	N14500808	YH-5/30, YH-5/80, YH-5/150	Cylinder base	0.3
AYH-5-2	N14500809	YH-5/30, YH-5/80, YH-5/150	Piston	0.3
AYH-10-1	N14500810	YH-10/30, YH-10/80, YH-10/150, YH-10/250	Cylinder base	0.6
AYH-10-2	N14500811	YH-10/30, YH-10/80, YH-10/150, YH-10/250	Piston	0.6
AYH-20-1	N14500812	YH-20/150, YH-20/250	Cylinder base	2.1
AYH-20-2	N14500813	YH-20/150, YH-20/250	Piston	2.1

### Dimensions AYH

Model	AYH-5-1	AYH-5-2	AYH-10-1	AYH-10-2	AYH-20-1	AYH-20-2
A, mm	M27 x 2	M18 x 1.5	M36 x 2	M27 x 2	M45 x 2	M36 x 2
B, mm	-	35	-	40	-	70
C, mm	35	35	38	38	50	50
D, mm	35	35	42	42	65	65
E, mm	15	15	25	25	35	35
F, mm	16	16	20	20	30	30
G <sup>1</sup> , mm	M35 x 1.5	-	M40 x 1.5	-	M70 x 2	-
H, mm	-	-	-	21	-	24
J, mm	18	-	21	-	23	-

<sup>1</sup>G = retainer nut according to DIN 981

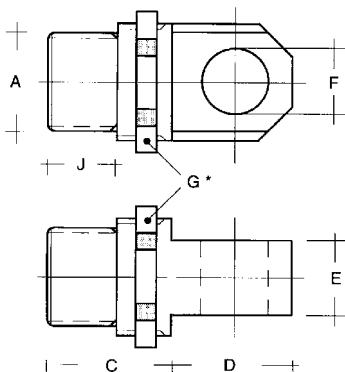

AYH-...-1 for cylinder base

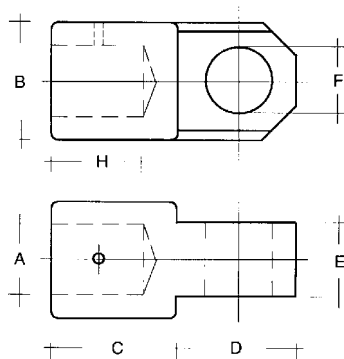

AYH-...-2 for piston



# INFO

## Build-up and description of Yale hand pumps

Hand pumps are the most common power source within the area of "High-Pressure Hydraulic Tools". For this reason our hand pumps have been carefully designed and equipped with many details which make the pumps very versatile and handy in every-day applications.

### Relief valve/hand wheel

The fine-adjustment relief valve in connection with the large hand wheel allows millimeter increments when lifting and lowering even highest loads. The fact that sometimes hundreds of tons are controlled by this hand wheel underlines the importance of this feature.

### Sturdy "all-metal-design"

The robust pump head and the absence of any plastic parts result in a long service life and easy maintenance over many years. Plastic reservoirs filled with oil may present a fire risk in connection with welding or similar work!

### Carrying handle

A handy carrying handle on all our hand pumps facilitates transportation enormously.

### Pressure relief valves

All hand pumps are equipped with two pressure relief valves. They are easily adjustable from outside if pumps must be re-adjusted or a lower operating pressure should not be exceeded.

### Reservoir ventilation

All hand pumps are equipped with a reservoir ventilation plug. This ensures perfect suction of hydraulic oil and allows you to use the total oil capacity of the reservoir.

### Two-stage output

All hand pumps have two-stage design (except HPS-1/0,7). This allows an increased speed and efficient working during unloaded conditions of the hydraulic cylinder. The switch-over from the low pressure to the high pressure stage is done automatically.

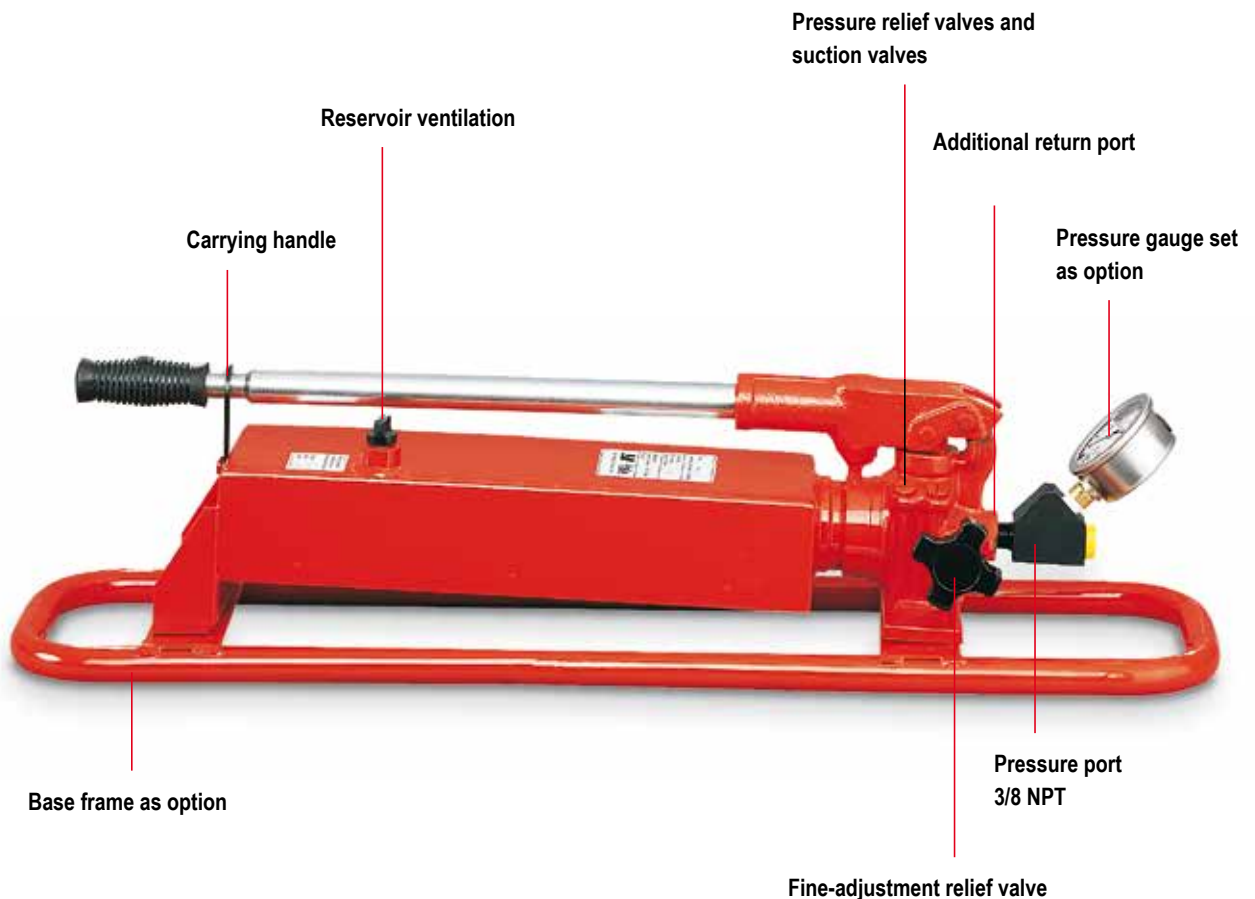

**Delivered ready to use**

All hand pumps are supplied ready to use incl. hydraulic oil.

**Easy-maintenance-design**

There is no need to disassemble the hand pumps in case of service work. All parts like suction and pressure valves, seals, packings etc. are accessible from the outside.

**All hand pumps have the same design**

The same design (build-up) for all hand pumps with the exception of the reservoirs allows the interchangeability of all components. Therefore spare part stocks can be kept to an absolute minimum. Only one spare part kit is necessary to service all hand pumps.

**Excellent suction properties**

Hand pumps suck and displace 100 % of their volume per stroke. This results both in a high efficiency as well as a rapid cylinder movement.

**Interchangeability**

All hydraulic cylinders, hand pumps and other components are fully interchangeable and can be combined with all other 700 bar hydraulic lines. All components have the standard oil port and same coupler parts.

**Additional return oil port**

All hand pumps are equipped with a return port to the reservoir. This detail is very advantageous as many hand pumps are integrated in more complex hydraulic circuits.

**Base frame**

On request you can get base frames for the most common hand pumps. These base frames add to the stability and protection of the hand pumps, in particular when used in the field or on a construction site.

**Pressure gauge**

Appropriate pressure gauges with the corresponding adaptors are shown in this catalogue.

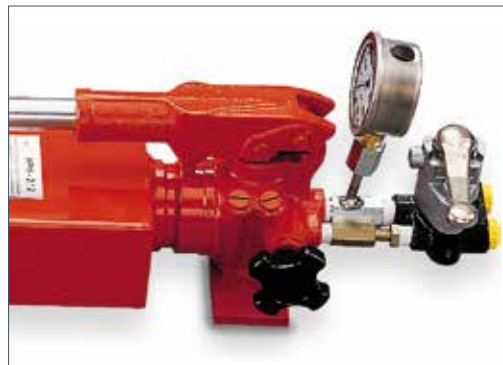

Hand pump HPH...

With integrated pressure gauge GGY-631 and gauge adaptor set GA-704.

**Hand pumps for double-acting cylinders with relief valve and 4/3-way directional valve**

Unlike conventional pumps, all hand pumps of the model HPH (with 4/3-way directional valve for double-acting cylinders) include a precision relief valve in addition to the directional control valve. Manual directional control valves switch over abruptly, thus causing undesired pressure surges in the system under load.

The additional relief valve in all HPH-hand pumps allows a precise lowering of the load without any pressure shocks. All components have the standard oil port and same coupler parts.

**Further advantage of this design:**

The pressure gauge shows the pressure as pushing and as pulling force. The combination of a 4-way directional valve with a sensitive relief valve allows a controlled pressure relief without pressure shocks.

OFFLINE

**INFO**

Selection charts "cylinder/hand pumps" can be found on pages 438 - 439.



## HPS Hand pumps for single-acting cylinders

Hand pumps are easy to use and operate independently of any external energy source. They are designed for a maximum 700 bar system pressure and will allow each hydraulic cylinder to utilize its maximum capacity.

The two-stage system reduces pumping time.

Stage 1 allows rapid piston travel under no load or light load conditions. The pump automatically switches to stage 2 when the piston is loaded and a higher force is required from top. The hand pump is an all-steel construction designed for rough use and has a high-efficiency pumping action. The handle can be locked for easy carrying.

The large and easy-to-control return valve allows the operator to precisely control the return stroke. Other standard features include a large and easy-to-control hand wheel, air bleeding and oil filling plug, large support feet for stability, tilted tank to increase usable oil volume and ergonomic handle grip.

### Features

- Operating pressure max. 700 bar.
- Two-stage operation with automatic switch-over (except HPS-1/0,7 A).
- Large reservoir volumes.
- With pressure relief valves, adjustable from the outside.
- Precision-adjustable relief valve (handwheel).
- Robust all-steel construction.
- HPH-pumps are equipped with a 4-way control valve plus a precision-adjustable relief valve.
- Oil port thread 3/8 NPT.
- Incl. oil filling.

### Optional

- Pressure gauges with corresponding adaptors are also available as accessories.

## INFO

Hydraulic hoses are the connection between hand pump and hydraulic cylinders and need to be selected separately. Please see page 413.

**Technical data HPS**

Model	Art.-No.	Displacement	Reservoir volume cm <sup>3</sup>	Displacement 1 <sup>st</sup> stage cm <sup>3</sup>	Displacement 2 <sup>nd</sup> stage cm <sup>3</sup>	Weight kg
HPS-1/0,7 A	N12101011	single-stage	700	–	2	7.0
HPS-2/0,3 A	N12101127	two-stage	300	5	1	3.5
HPS-2/0,7 A	N12101012	two-stage	700	11	2	7.0
HPS-2/1,3 A	192085595	two-stage	1300	11	2	9.0
HPS-2/2 A	N12101013	two-stage	2000	11	2	10.0
HPS-2/4 A	N12101014	two-stage	4000	11	2	13.0
HPS-2/6 A	N12101015	two-stage	6000	11	2	21.0
HPS-2/10 A	N12101016	two-stage	10000	11	2	27.0

**Dimensions HPS**

Model	HPS-1/0,7 A	HPS-2/0,3 A	HPS-2/0,7 A	HPS-2/1,3 A	HPS-2/2 A	HPS-2/4 A	HPS-2/6 A	HPS-2/10 A
A, mm	505	410	505	630	520	645	645	800
B, mm	85	100	85	80	70	65	65	65
C, mm	135	105	135	135	145	160	215	250
D, mm	150	125	150	150	150	150	180	190
E, mm	43	35	43	43	43	43	43	43
F, mm	52	35	52	52	52	52	52	52

Dimensions approx.

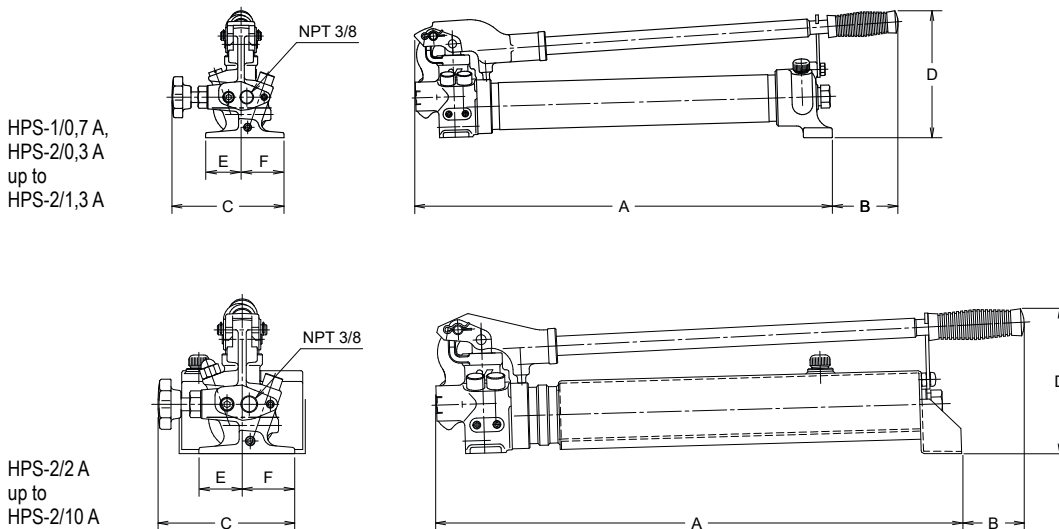



depicted pressure gauge optional

## HPH Hand pumps for double-acting hydraulic cylinders

**With 4-way valve and relief valve (hand wheel)**

All hand pumps of type HPH are designed as double-acting cylinders. Basically, they do not differ from series HPS, but are equipped with a 4/3-way directional valve.

The precision-adjustable relief valve remains unaffected and permits a sensitive pressure relief.

### Optional

- Pressure gauges with corresponding adaptors are also available as accessories.

### Technical data HPH

Model	Art.-No.	Displacement	Reservoir volume cm <sup>3</sup>	Displacement 1 <sup>st</sup> stage cm <sup>3</sup>	Displacement 2 <sup>nd</sup> stage cm <sup>3</sup>	Weight kg
HPH-2/0,7 A	N12101018	two-stage	700	11	2	8
HPH-2/2 A	N12101019	two-stage	2000	11	2	11
HPH-2/4 A	N12101020	two-stage	4000	11	2	14
HPH-2/6 A	N12101021	two-stage	6000	11	2	22
HPH-2/10 A	N12101022	two-stage	10000	11	2	28

### Dimensions HPH

Model	HPH-2/0,7 A	HPH-2/2 A	HPH-2/4 A	HPH-2/6 A	HPH-2/10 A
A, mm	505	520	645	645	800
B, mm	85	70	65	65	65
C, mm	160	160	160	200	160
D, mm	150	150	150	180	190
E, mm	43	43	43	43	43
F, mm	52	25	52	52	52
G, mm	85	85	85	85	85

Dimensions approx.

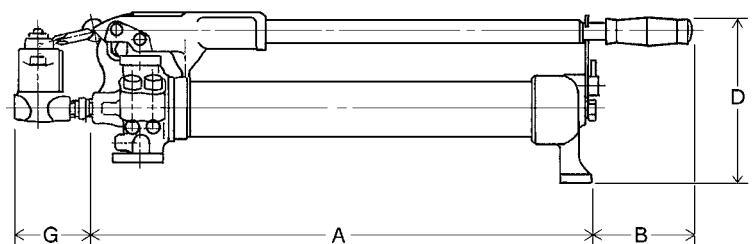
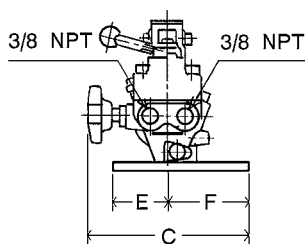

## HPB

### Base frames for hand pumps

These base frames add to the stability of your hand pump, in particular when used in the field or on a construction site where hand pumps are frequently operated on uneven and soft ground.

At the same time, the hand pumps are protected from sand, humidity and possible damage.

The assembly of the base frames is very easy; just three holes have to be bored to mount the frame to the hand pump.



### Technical data HPB

Model	Art.-No.	Suitable for hand pump	Weight kg
HPB-2	N14500205	HPS-1/0,7 A + HPS-2/0,7 A + HPS-2/2 A + HPH-2/0,7 A + HPH-2/2 A	1.3
HPB-4	N14500206	HPS-2/4 A + HPS-2/6 A + HPH-2/4 A + HPH-2/6 A	1.8

### Dimensions HPB

Model	HPB-2	HPB-4
A, mm	765	885
B, mm	190	190

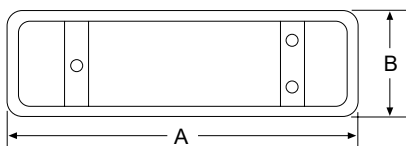



## TWAZ Hand pumps

### Operating pressure max. 2000 bar

These high-performance hand pumps allow a very rapid pressure build-up due to their two-stage design. Both pressure stages are equipped with a limiting valve which can easily be adjusted from outside.

High-pressure hand pumps are used for special applications like pressurizing hydraulic nuts and safety couplings, hydrostatic testing, bolt tensioners, high-pressure oil injection for bushing removal, pretensioning anchors, for test applications in laboratories and as a power source within test stands and propeller press systems.

### Accessories for hand pumps TWAZ



Optional: Pressure gauge, GGY-2500.



Optional: Pressure gauge adaptor, GA-2000.



Optional: Adaptor, FY-201 (M22 x 1.5 on G 1/4).



Optional: Hydraulic hoses, HH-2001-20, pressure max.: 2000 bar.

### Technical data TWAZ

Model	Art.-No.	Pressure max. bar	Reservoir volume cm <sup>3</sup>	Displacement 1 <sup>st</sup> stage cm <sup>3</sup>	Displacement 2 <sup>nd</sup> stage cm <sup>3</sup>	Oil port	Pressure gauge	Pressure gauge model	Pressure gauge adaptor model	Pressure relief valve	Weight kg
TWAZ-0,7	N12201100	2000	700	8	0.6	M22 x 1.5	optional	GGY-2500	GA-2000	yes	7.0
TWAZ-1,3	N12201101	2000	1300	13	1.0	M22 x 1.5	optional	GGY-2500	GA-2000	yes	9.0
TWAZ-2,3	N12201102	2000	2300	31	1.6	M22 x 1.5	optional	GGY-2500	GA-2000	yes	16.0

## FPS Foot pumps

### Operating pressure 700 bar

Used to operate single-acting hydraulic cylinders, especially for repeated applications, such as checking of welding samples, pressing of connection components (crimping), actuating of clamping devices, as well as for all applications, where it is necessary to keep hands free.

The pump can be used everywhere, as it is independent of an external energy source and is easily portable. An extremely good stability guarantees a comfortable and safe operation up to the highest pressure. It is a “real” foot operated pump, as the return stroke of the connected hydraulic cylinder is released by foot control.

### Features

- Operating pressure max. 700 bar.
- Absolute stability due to large base plate.
- Minimized labour fatigue.
- Operating pressure adjustable. Valves accessible from the outside.
- Return stroke of cylinder also controlled by foot operation.
- Oil port 3/8 NPT.

### Optional

- Pressure gauges and suitable adaptors.
- Hydraulic hoses



### Technical data FPS

Model	Art.-No.	Operating pressure max. bar	Displacement 1 <sup>st</sup> stage cm <sup>3</sup>	Displacement 2 <sup>nd</sup> stage cm <sup>3</sup>	Reservoir volume useable cm <sup>3</sup>	Weight kg
FPS-2/0,5 A	N12501128	700	11	2	500	7





## PY-04 Electric motor pumps, portable

### Operating pressure max. 700 bar

These light-weight but powerful two-stage pumps are particularly designed for maintenance and repair jobs. Depending on their type, they can either operate single-acting or double-acting hydraulic cylinders.

The ideal combination of manually operated valve and remote pendant control provides the operator with ample freedom of motion and ensures a safe "holding of the load".

The remote pendant control (1.5 m) is used to start the motor even under full load. The function for both manual valves is as follows: - **advance** - **hold** - **return** - With their light weight and convenient carrying handle, these pumps can be easily transported. Pumps are equipped with thermal overload protection and are supplied with hydraulic oil:

### Operation of the power pump

#### PY-04/2/5/2E:

By activating push-button number 1, the motor starts and the cylinder advances. In the neutral position the pressure is held. By activating push-button number 2, the solenoid valve is activated, the pressure decreases and the hydraulic cylinder retracts.

### Operation of the power pump

#### PY-04/2/5/2M:

The 2/2-way manual valve operates together with a pilot operated unloading valve, so that the two valve positions result in the following two control possibilities:

Valve handle position 1:

Cylinder holds pressure after motor stop.

Valve handle position 2:

Cylinder automatically retracts after motor stop.

### Technical data PY-04

Model	Art.-No.	Control valve	Operating pressure max. bar	No load stroke l/min up to 30 bar	Under load stroke l/min up to 700 bar	Useable reservoir volume l	Connecting value	Cable remote control m	Speed rpm	Protection standard	Weight, without oil, approx. kg
PY-04/2/5/2 M	N12300132	2/2-way manual valve	700	4.0	0.23	5.0	0.37 kW - 230 V-1Ph	1.5	2800	IP 50	24
PY-04/2/5/4 M	N12300193	4/3-way manual valve	700	4.0	0.23	5.0	0.37 kW - 230 V-1Ph	1.5	2800	IP 50	26
PY-04/2/5/2 E	N12300043	2/2-way solenoid valve	700	4.0	0.23	5.0	0.37 kW - 230 V-1Ph	1.5	2800	IP 50	28

**PAY**  
**Mini hydraulic pumps,**  
**with compressed air**  
**driven motor**

**Operating pressure max. 700 bar**

These mini-pumps are driven by an air-powered motor and can be connected to any supply source of compressed air. These compact low-cost pumps can operate all single-acting or double-acting hydraulic cylinders up to a max. operating pressure of 700 bar.

Due to large reservoirs, large cylinders or multiple cylinders can be operated. The use of an inline air filter-lubricator is recommended.

The hydraulic pressure can be infinitely adjusted on the regulator of the air-lubricator unit. The air-driven motor guarantees 100 % explosion protection.

Pumps for double-acting hydraulic cylinders are equipped with an additional 4-way control valve type VHH-4/3.

The connected hydraulic cylinder is controlled - **advance** - **hold** - **return** - by the universal pedal, which can be either hand or foot-operated.

**Control of cylinder motion**

- Pedal in neutral position – motor stands still, cylinder stands, pressure is held.
- Pedal depressed – motor starts, cylinder advances, pressure is built-up.
- Pedal pushed forward – motor stands still, pressure is released, cylinder retracts.



**Technical data PAY**

Model	Art.-No.	For cylinders	Reservoir volume l	Oil pressure max. bar	Oil displacement l/min	Required air pressure bar	Air consumption l/min	Oil port	Air port	Weight kg
PAY-6	N12300133	single-acting	1.5	700	1.28 - 0.14	7	560	3/8 NPT	1/4 NPT	6.3
PAY-6-5	N12300715	single-acting	5.0	700	1.28 - 0.14	7	560	3/8 NPT	1/4 NPT	12.0
PAY-64	N12300279	double-acting	1.5	700	1.28 - 0.14	7	560	3/8 NPT	1/4 NPT	7.5
PAY-64-5	N12300006	double-acting	5.0	700	1.28 - 0.14	7	560	3/8 NPT	1/4 NPT	13.0

INFO



PY-11/3/20/4 M



PY-07/3/10/3 E

## PYE and PY Electric hydraulic power packs

### Single-stage and two-stage

Power packs are easy to operate as they are fully assembled and easy to control.

The use of power packs is always recommended when jobs have to be done in a time-saving and efficient way, when repeating jobs have to be finished off, quick cylinder cycles have to be achieved or if large oil volumes in connection with high-tonnage cylinders have to be transmitted.

### Two-stage output

The standard power packs are equipped with two-stage pumps, which means that a low pressure stage fills the connected hydraulic cylinder quickly up to a pressure of 80 bar. The high pressure stage is activated automatically from 80 bar up to 700 bar, while the low pressure stage is discharged back to the reservoir. This economic solution avoids heating-up, saves energy and keeps the power packs compact.

### Single-stage output PYE

The hydraulic packs have single-stage pumps. These packs deliver between 0 and 700 bar with the same volume (high-pressure stage).

### Control/Operation

The motion control of the connected hydraulic cylinder is done by operating the directional valve.

### Do you have a single-acting or a double-acting hydraulic cylinder?

The directional control valve has to correspond to the a.m. functional principle of the hydraulic cylinder to be operated. Depending on these principles the power packs are equipped with a:

- 3/3-way valve to operate single-acting hydraulic cylinders (connection with one hydraulic hose)
- 4/3-way valve to operate double-acting hydraulic cylinders (connection with two hydraulic hoses)

The directional control valves are available either as manual or solenoid operated valves.

### Operation of the directional valves

Depending on the way of operation, there are manual or solenoid operated valves. Manual valves are controlled by shifting the operating lever and represent the economic way of control.

These valves have 3 lever positions:

- advance - hold - return -

### Solenoid valves

Solenoid valves have the advantage that they are controlled by a pendant remote control box which makes the operator independent from the power pack, making it easier for him to monitor the job.

The solenoid valves are controlled by two push-buttons – **advance** – **return** –

In neutral position – **hold** – the valves rest in pressureless circuit. Pressure and force of the connected cylinder are held without pressure drop. The complete electrical set-up (with 24 V control) belongs to the scope of delivery. Solenoid valves allow a very ergonomic operation and offer a quick and precise switching (millimeterwise) of the connected hydraulic cylinder.

### Pressureless circuit

In neutral position all directional valves rest in pressureless circuit which means that the oil flow coming from the rotating pump is guided back to the reservoir without creating any pressure build-up.

### Special solenoid valve configurations

Some applications require a special valve configuration, e.g. the independent control of several hydraulic cylinders from a single power pack. In such cases the complete valve build-up and electrical control is designed according to customer's requirements.

### Pressure-guard power packs

By using an electro-hydraulic pressure switch and a special electric control, power packs automatically control their pre-adjusted pressure. In applications where the pressure (load) should be applied over a very long period, the connected power pack is switched on and off automatically and replaces the pre-set pressure in case a pressure drop has occurred.

### Trolleys

For all power packs we offer a cart-frame for flexible movement from job to job. Cart-frames are equipped with 2 fixed and 2 swivel castors.

### Oil cooler

For certain applications, especially when power packs are continuously operated and the oil temperature could exceed 60°C, the use of an oil cooler is recommended.

### Hydraulic oil

All power packs are designed for an operation with standard hydraulic oil (specification ISO VG 32).

For certain operating conditions the viscosity class of the hydraulic fluid can be varied.

All power packs are supplied including oil.

### Features

- Robust packs, also capable for continuous applications.
- Suitable for all jobs in workshops and on construction sites where hydraulic force is required; supplied ready to use.
- On-off motor switch and 3 m motor connecting cable.
- With carrying handles, oil level gauge, oil filler/reservoir ventilation plug.
- Incl. pressure gauge GGY-631.
- Two-stage displacement, which means a rapid advance without load, as well as an automatic switch into the 2. phase by a congruous load.
- Low noise level due to standard motors with 1450 U/min.
- Further motor voltage and oil reservoirs on request.
- With manual or solenoid operated directional valves.
- Solenoid valves with 3 m remote control box (with 2 push-buttons) and pressure set valve as standard. Adjustable from 0 - 700 bar.
- 24 V - low voltage control includes a sturdy metal electric control box and ready to use set up.



## Two-stage electric hydraulic power packs, 700 bar

Model	Reservoir size				Control valve (directional valve)				Motor power kw	Displacement, two-stage	
	10 l	20 l	30 l	50 l	manual valve		solenoid valve			approx. l/min 0-80 bar	approx. l/min 80-700 bar
					3/3-way	4/3-way	3/3-way	4/3-way			
PY-07/3/10/3 M	•	–	–	–	•	–	–	–	0.75	6.0	0.6
PY-07/3/10/4 M	•	–	–	–	–	•	–	–	0.75	6.0	0.6
PY-07/3/20/3 M	–	•	–	–	•	–	–	–	0.75	6.0	0.6
PY-07/3/20/4 M	–	•	–	–	–	•	–	–	0.75	6.0	0.6
PY-07/3/20/3 E	–	•	–	–	–	–	•	–	0.75	6.0	0.6
PY-07/3/20/4 E	–	•	–	–	–	–	–	•	0.75	6.0	0.6
PY-11/3/20/3 M	–	•	–	–	•	–	–	–	1.1	8.5	1.0
PY-11/3/20/4 M	–	•	–	–	–	•	–	–	1.1	8.5	1.0
PY-11/3/30/3 M	–	–	•	–	•	–	–	–	1.1	8.5	1.0
PY-11/3/30/4 M	–	–	•	–	–	•	–	–	1.1	8.5	1.0
PY-11/3/20/3 E	–	•	–	–	–	–	•	–	1.1	8.5	1.0
PY-11/3/20/4 E	–	•	–	–	–	–	–	•	1.1	8.5	1.0
PY-11/3/30/3 E	–	–	•	–	–	–	•	–	1.1	8.5	1.0
PY-11/3/30/4 E	–	–	•	–	–	–	–	•	1.1	8.5	1.0
PY-22/3/30/3 M	–	–	•	–	•	–	–	–	2.2	18.0	2.1
PY-22/3/30/4 M	–	–	•	–	–	•	–	–	2.2	18.0	2.1
PY-22/3/50/3 M	–	–	–	•	•	–	–	–	2.2	18.0	2.1
PY-22/3/50/4 M	–	–	–	•	–	•	–	–	2.2	18.0	2.1
PY-22/3/30/3 E	–	–	•	–	–	–	•	–	2.2	18.0	2.1
PY-22/3/30/4 E	–	–	•	–	–	–	–	•	2.2	18.0	2.1
PY-22/3/50/3 E	–	–	–	•	–	–	•	–	2.2	18.0	2.1
PY-22/3/50/4 E	–	–	–	•	–	–	–	•	2.2	18.0	2.1

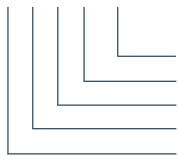

### Code explanation

- Directional valve : 3 = for single-acting, 4 = for double-acting cylinder, M = manual valve, E = solenoid valve
- Reservoir size : in liters (other reservoir sizes on request)
- Motor voltage : 3 = 380-420 V, 3-phase (Euro-voltage), 2 = 230 V, 1-phase, (other voltages on request)
- Hoist motor : 07 = 0.75 kW, 11 = 1.1 kW, 22 = 2.2 kW, 30 = 3 kW, 55 = 5.5 kW, 75 = 7.5 kW, 110 = 11 kW
- Type of motor : PY = electric motor, PAY = air motor, PGY = petrol driven motor (4 cycle)

## Single-stage electric hydraulic power packs, 700 bar

Model	Reservoir size				Control valve (directional valve)				Motor power kw	Displacement l/min 0-700 bar
	10 l	20 l	30 l	50 l	manual valve		solenoid valve			
					3/3-way	4/3-way	3/3-way	4/3-way		
PYE-03/3/10/3 M	•	–	–	–					0.35	0.3
PYE-03/3/10/4 M	•	–	–	–					0.35	0.3
PYE-07/3/10/3 M	•	–	–	–					0.75	0.6
PYE-07/3/10/4 M	•	–	–	–					0.75	0.6
PYE-07/3/20/4 M	–	•	–	–	All valve and reservoir combinations available.				0.5	0.6
PYE-11/3/20/3 M	–	•	–	–					1.1	1.0
PYE-11/3/20/4 M	–	•	–	–					1.1	1.0
PYE-11/3/30/4 M	–	–	•	–					1.1	1.0
PYE-22/3/20/3 M	–	•	–	–					2.2	2.1
PYE-22/3/20/4 M	–	•	–	–					2.2	2.1
PYE-22/3/30/4 M	–	–	•	–					2.2	2.1
PYE-22/3/50/4 M	–	–	–	•					2.2	2.1

## High-performance electric hydraulic power packs, 700 bar, single-stage

Model	Reservoir size				Control valve (directional valve)				Motor power kw	Displacement l/min 0-700 bar
	50 l	70 l	100 l	150 l	manual valve		solenoid valve			
					3/3-way	4/3-way	3/3-way	4/3-way		
PYE-40/3/50/4 M	•	–	–	–	All valve and reservoir combinations available.				4.0	2.7
PYE-55/3/70/4 M	–	•	–	–					5.5	4.0
PYE-75/3/100/4 M	–	–	•	–					7.5	6.0
PYE-110/3/150/4 M	–	–	–	•					11.0	8.0
PYE-180/3/150/4 M	–	–	–	•					18.0	12.0

### Hydraulic power pack with protection cage

This power pack is specially designed for general lifting applications in construction areas. Equipped with an optimized valve configuration, including 4-way manual directional valve VHP-4/3-1, safety-check valve VSM-21, pressure relief valve VPR-1 and two pressure gauges for permanent load control.



### Hydraulic power pack with 4-way manifold MY-44-GYA

The most economic way for a pressure-independent and individual control of four single-acting hydraulic cylinders. The additionally mounted safety-check valve VSM-21 avoids uncontrolled pressure drops, and the built-in throttle valve allows a precise (millimeterwise) lowering even of the highest loads. Four pressure gauges allow a permanent reading of the individual loads. On request, the power packs can be equipped with a handy cart-frame to make the operation flexible. This type of power pack can be supplied in all sizes of the PY and PYE series.



### Hydraulic power pack with 4-times solenoid valve

The quadruple solenoid valve block ensures a pressure-independent and individual control of four double-acting hydraulic cylinders. Solenoid valves offer several well-known advantages such as: ergonomic and safe control by pendant remote control, exact load hold, precise and quick switch characteristics and many more.



### Double-hydraulic power pack

In order to realise very high oil flows, two independent pump systems can be combined in one large reservoir. A gear pump ensures an extremely high oil flow up to 250 bar while the high-pressure stage is generated by a high-performance radial piston pump. Each pump is equipped with its own solenoid control valve so that the individual oil flows can be generated or discharged on request.



INFO

### The Yale electric power pack PYB

Hand pumps are the most common power source within the area of "High-Pressure Hydraulic Tools". Using a hand pump can require a higher force. The new cordless power pack PYB is a highly efficient replacement for a standard hydraulic hand pump.

Adding this pump to our sales programme enables us to offer four pump types - giving the user more flexible options to choose from.

#### Relief valve

The fine-adjustment relief valve in connection with the lever allows millimeter increments when lifting and lowering even the highest loads. The fact that sometimes hundreds of tons are controlled by this hand wheel underlines the importance of this feature.

### Robust aluminium/metal construction

The aluminium die-cast housing ensures low weight and protects the battery. Plastic reservoirs filled with oil may present a fire risk in connection with welding or similar hot work!

#### Shoulder belt

A shoulder belt can be attached to the lifting eyes making it easier to carry the pump.

#### Pressure relief valves

The electric power packs PYB are equipped with two internal pressure relief valves.

The high pressure stage is set to a maximum operating pressure of 700 bar, to avoid over-pressurization of the system.

NEW DEVELOPMENT  
**CORDLESS TECHNOLOGY!**  
 FOR MOBILE OPERATION

Protective cover to accidental operation on of pump



**Rubber tank bladder**

The rubber tank bladder of the PYB enables the pump to be used in any position. The total available oil volume can be used.

**Two-stage output**

Both PYB power packs have a two-stage design. This allows increased speeds and efficient working during unloaded conditions of the hydraulic cylinder. The switch-over from the low pressure to the high pressure stage is done automatically.

**Both pumps PYB are “identical”.**

Except for the reservoir and the cover both units are identical. Which means that nearly all parts are interchangeable.

So keeping spare parts can be minimized, e.g. only one seal kit has to be stocked to service both pumps.

**Excellent suction properties**

Hand pumps draw and displace 100% of their volume per stroke. This results both in a high efficiency as well as a rapid cylinder movement.

**Interchangeability**

All hydraulic cylinders, hand pumps and other components are fully interchangeable and can be combined with all other 700 bar hydraulic lines. The PYB is equipped with a female coupler half CFY-1.

**Pressure gauge**

Appropriate pressure gauges with the corresponding adaptors are shown in this catalogue.



**Cordless power pack: PYB-1.0 c/w optional gauge adaptor set GYA-63.**

**Battery and charger**

The Batterys and chargers are HiKOKI original parts and are commercially available. Which means every customer can decide if and how many Batterys and chargers they want to order with Columbus McKinnon or if they want to purchase the necessary parts locally.

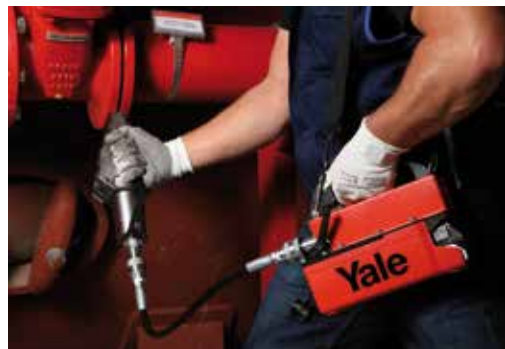

ONE  
FINE

**Possible applications and devices to be combined**



**Lifting wedges**  
HK-16T  
16t



**Spreading wedges**  
YSW-14T,  
14t



**Low-profile and flat cylinders**  
YLS and YFS,  
10 - 100t



**Spreaders**  
YHS,  
0,5 - 1,5t



**Nut splitters**  
YNS/YNS-AH,  
SW 11 - 89mm





PYB-1,0  
with optional  
pressure gauge  
GYA-63

PYB-0,6



Ideal application in combination with compact, portable hydraulic tools like spreaders, lifting wedges, low profile and flat cylinders as well as nut splitters

## PYB Elektric power pack, battery driven

### Operating pressure max. 700 bar

The Yale PYB cordless power pack provides a flexible edition to the Yale hydraulic programme.

This extremely compact and lightweight power pack gives the user the freedom to operate in areas where there is no power source, increasing productivity over the conventional hand pump and all at the push of a button.

The power pack utilises a standard HiKOKI LI-ION battery and charger to maximize operation.

Ideal for a range of applications using small to mid size single-acting cylinders, hydraulic spreaders, lifting wedges nut splitters and much more.

### Features

- Operating pressure max. 700 bar.
- One-Hand-Operation. Push-button integrated into ergonomic handle.
- Two-stage operation with automatic switch-over.
- With internal pressure relief valve.
- Reservoir made from aluminium, extreme low weight.
- Protective cover to prevent inadvertent switch on of pump.
- Rubber tank bladder enables the pump to be used in any position.

### Optional/Accessories

**Standard HiKOKI Batterys (Typ BSL36A18x2) and chargers are exclusively used.**

- Battery PYB-BAT, 18V, weight 0.7 kg  
Art.-No. 192043950
- Quick-charger PYB-CHARG,  
230 V and 12 V (car plug socket incl.)  
Art.-No. 192043961
- Pressure gauge set GYA-63 consisting of:  
Gauge GGY 632, Ø63 mm, 0 - 1000 bar and adaptor.  
Art.-No. N14200497
- Hydraulic hose HHC (to complete the connection a male coupler half CMY-1 is required)

### Scope of delivery

- Electric power pack, battery driven
- Oil filled ready for work
- Female coupler half CFY-1
- Shoulder belt

## Technical data PYB

Model	Art.-No.	Displacement	Reservoir volume	Displacement 1 <sup>st</sup> stage	Displacement 2 <sup>nd</sup> stage	Weight without battery	Operational weight c/w battery
			cm <sup>3</sup>	l/min	l/min	kg	kg
PYB-0,6	192043421	two-stage	600	0.7	0.06	4.8	5.5
PYB-1,0	192043988	two-stage	1000	0.7	0.06	5.7	6.4

## Dimensions PYB

Model	PYB-0,6	PYB-1,0
A, mm	245	290
B, mm	100	100
C, mm	120	120
D, mm	200	229
E, mm	148	166
F, mm	88	106

Dimensions approx.

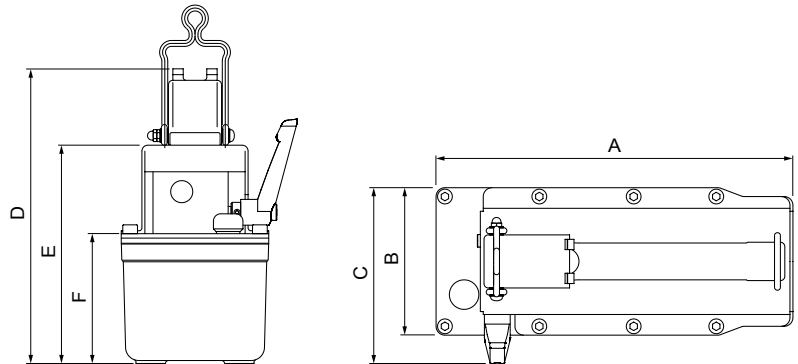

## INFO

Battery and charger are NOT supplied in the standard scope of delivery. These items must be ordered separately.

## Comparison

Cylinder size t	Hand pump		Electric power pack PYB	
	No. of pump strokes for 10 mm stroke		Piston travel speed	
	HPS-2/0,7A up to HPS-2/10A LP	HPS-1/0,7A up to HPS-2/10A HP	LP	HP
5	1	4	16.2	1.4
10	1	7	8.2	0.7
15	2	11	5.4	0.5
20	2	14	4.1	0.35
21	2	15	3.8	0.33
23	3	17	3.5	0.3
30	3	22	2.7	0.23

LP = Low-pressure stage (unloaded stroke)  
HP = High-pressure stage (loaded stroke)



Shoulder belt



Hydraulic hose  
HHC



Optional pressure gauge set  
GYA-63



Quick-charger  
PYB-CHARG



Battery  
PYB-BAT



One-Hand-Operation  
Push-button integrated into ergonomic handle.



PMF-15/3/40/4 x 3 M

## PMF Multiple-flow hydraulic power packs

Multiple-flow hydraulic pumps can advance four cylinders with the same speed at the same time by injecting equal amounts of hydraulic oil into each individual cylinder. This principle allows a synchronized lifting of machines or similar loads from a central point. Even under different loading conditions the cylinders advance in synchronisation.

Levelling of a lopsided load is easily possible by an individual control of each single cylinder. The lifting phase is initiated by a push-button remote control box and can be interrupted and continued at any time.

Lowering of the load is done by operating the directional valve in connection with the throttle valve individually for each circuit. The multiple-flow pumps can drive all kinds of hydraulic cylinders, machine jacks or stage lifts.

### Features

- 4-point synchronized lift due to 4 equal, independent and individual oil flows.
- 4 manually operated directional valves, or 4 solenoid directional valves allow an individual or joint control of all 4 connected cylinders (easy levelling of loads).
- Safe load hold due to check valve in each circuit.
- One-man central operation.
- Motor on-off switch by means of a pendant remote control box in connection with manual valves
- A complete remote control box to operate the solenoid valves.

### Optional

- All pump packs are also available with 4/3 direction-valves (for controlling the double-acting hydraulic cylinders).
- All power packs can be supplied with a protection frame suitable for on-site operation.  
Also cart-frames with 2 fixed and 2 swivel castors are available on request.

### Scope of delivery

For each of the four circuits the ready-to-use supply includes: glycerine-damped pressure gauge, 3-way control valve, safety-check valve, a female coupler-half as connecting port. Furthermore: hydraulic oil, carrying handles, motor on-off switch, motor connecting cable, pendant remote control, electro-box with transformer and motor relays, oil level gauge and oil-filler/ventilation plug. All multiple-flow power packs are also available with 4-way directional valves in order to operate double-acting hydraulic cylinders.

## INFO

All extra loads can be meter-read permanently.

## PMF 4-multiple-flow power packs with solenoid directional valves

4-multiple-flow power packs with solenoid directional valves to advance 4 hydraulic cylinders independently and in a synchronized way by means of solenoid valves with a pendant remote control box.

The solenoid valves in connection with safety-throttle valves allow a precise control of all connected hydraulic cylinders.



PMF-15/3/40/4 x 4 E

### Technical data PMF

Model	Art.-No.	Operating pressure max. bar	Displacement l/min	Manual valve	Solenoid valve	Motor remote control	Reservoir size l	E-motor
PMF-07/3/20/2 x 3 M	N12300047	2 x 700	2 x 0.3	•	–	•	20	0.75 kW - 400 V - 3 Ph
PMF-07/3/20/2 x 3 E	–	2 x 700	2 x 0.3	–	•	–	20	0.75 kW - 400 V - 3 Ph
PMF-15/3/20/2 x 3 M	192018656	2 x 700	2 x 0.6	•	–	•	20	1.5 kW - 400 V - 3 Ph
PMF-15/3/20/2 x 3 E	–	2 x 700	2 x 0.6	–	•	–	20	1.5 kW - 400 V - 3 Ph
PMF-15/3/40/4 x 3 M	N12300924	4 x 700	4 x 0.3	•	–	•	40	1.5 kW - 400 V - 3 Ph
PMF-15/3/40/4 x 3 E	N12300003	4 x 700	4 x 0.3	–	•	–	40	1.5 kW - 400 V - 3 Ph
PMF-30/3/40/4 x 3 M	N12300007	4 x 700	4 x 0.6	•	–	•	40	3.0 kW - 400 V - 3 Ph
PMF-30/3/40/4 x 3 E	N12300005	4 x 700	4 x 0.6	–	•	–	40	3.0 kW - 400 V - 3 Ph
PMF-55/3/100/4 x 3 E	–	4 x 700	4 x 1.0	–	•	–	100	5.5 kW - 400 V - 3 Ph
PMF-110/3/100/4 x 3 E	–	4 x 700	4 x 2.1	–	•	–	100	11.0 kW - 400 V - 3 Ph

## INFO

All multiple-flow power packs are also available with 4-way directional valves in order to operate double-acting hydraulic cylinders model PMF.



This port can easily be used to connect a pressure gauge and a pressure relief valve (e.g. VPR-1). The oil port T shall always be connected to the reservoir without any back pressure.

## VHP and VHH Directional valves

### Manually operated, 700 bar

These directional valves control the oil flow in combination with hydraulic power packs (YHH-4/3 with hand pumps).

All valves have 3 lever positions to control movement of the connected hydraulic cylinder:

1. Left: cylinder advance.
2. Middle: cylinder neutral (pressureless circuit).
3. Right: cylinder retracts.

In the middle position (hold) the piston of the cylinder stops and the oil flow is guided in a circuit back to the reservoir (P to T). The valves can be flanged directly onto power packs but can also be connected by using hydraulic piping.

In addition, all valves are equipped with a second pressure oil port P at the back of the valve base.

### Technical data VHP and VHH

Model	Art.-No.	Pressure max. l/min	Size	Oil ports	Hydraulic symbol	Applications
VHP-3/3-1	N14100718	8 - 16	1	3/8 NPT		3/3-way valve with "open centre" in middle position (pressureless circuit) to control single-acting hydraulic cylinders
VHP-3/3-2	N14100720	20 - 40	2	3/8 NPT		
VHP-3/3-1 CC	N14100719	8 - 16	1	3/8 NPT		3/3-way valve with "closed centre" in middle position to control single-acting hydraulic cylinders!
VHP-3/3-2 CC	N14100721	20 - 40	2	3/8 NPT		
VHP-4/3-1	N14100227	8 - 16	1	3/8 NPT		4/3-way valve with "open centre" in middle position (pressureless circuit) to control double-acting hydraulic cylinders
VHP-4/3-2	N14100228	20 - 40	2	3/8 NPT		
VHP-4/3-1 CC	N14100322	8 - 16	1	3/8 NPT		4/3-way valve with "closed centre" in middle position to control double-acting hydraulic cylinders!
VHP-4/3-2 CC	N14100335	20 - 40	2	3/8 NPT		
VHH-4/3	N14100226	2 - 3	small special design	1/4 NPT		4/3-way valve with "open centre" in middle position (pressureless circuit) to control double-acting hydraulic cylinders. Special design to be mounted directly to all HPS hand pumps (with connecting set FY-703). Also suitable for small hydraulic power packs

## VEP

### Directional valves

#### Solenoid incl. pressure set valve, 700 bar

Solenoid operated valves are used to control the connected hydraulic cylinder by means of a pendant remote control or further electrical controls like pressure switches or limit switches.

#### Control principle

All solenoid valves have 3 positions:

**- advance - hold - return -**

In neutral position (- hold -) the valves switch to "pressureless circuit" so that the oil flow is guided back to the reservoir while the connected cylinder is safely held under pressure.

Normally, solenoid valves are mounted directly onto power packs but can also be connected by using hydraulic piping.

#### Design

Long-life, direct-control ball seal valves with leak-free "load hold function" in neutral position.

The solenoids guarantee a very quick reaction of the valves so that cylinders can be controlled millimeterwise.

The valves are suitable for continuous operation (100 % on/off duration).

#### Modular design

The modular principle allows special valve configurations e.g. control of multiple cylinder systems or specific control sequences.

#### Pressure adjustment

All solenoid valves are equipped with a precision-adjustable pressure set valve which allows the system pressure (force of cylinder) to be limited to any value from 0 to 700 bar.



VEP-3/3-1

VEP-4/3-1

#### Pressure gauge

A glycerine-damped pressure gauge GGY-631 is standard with solenoid valves, 0 - 1000 bar, Ø 63 mm.

#### Mounting flange

The valve flanges are designed in a way that valves (with pressure connector) can easily be mounted onto power packs.

#### Optional

The connector model FY-905 is to be ordered separately.

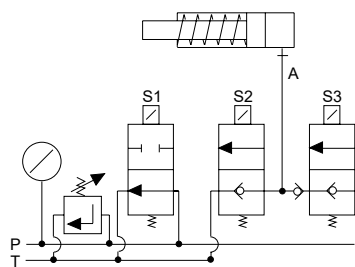

VEP-3/3-1 and VEP-3/3-2 for single-acting cylinders

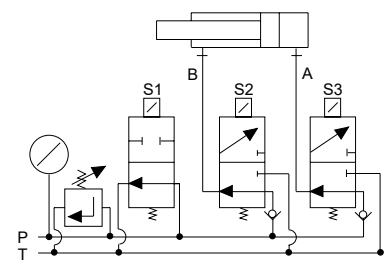

VEP-4/3-1 and VEP-4/3-2 for double-acting cylinders

## INFO

If oil ports A and B should have 3/8 NPT the adaptor model FY-30 is to be ordered separately.

### Technical data VEP

Model	Art.-No.	Control	For cylinders	Operating pressure max. bar	Size	Oil flow max. l/min	Control voltage	Oil ports P T	Pressure relief valve	Weight kg
VEP-3/3-1	N14100404	3/3-way	single-acting	700	1	12	24 V =	3/8 NPT	yes	4.1
VEP-3/3-2	N14100405	3/3-way	single-acting	700	2	25	24 V =	3/8 NPT	yes	7.9
VEP-4/3-1	N14100403	4/3-way	double-acting	700	1	12	24 V =	3/8 NPT	yes	4.1
VEP-4/3-2	N14100406	4/3-way	double-acting	700	2	25	24 V =	3/8 NPT	yes	7.9



### Selection advice

If the valve is to be screwed directly into a hydraulic cylinder, please order model VSM-11.

If the valve is to be combined with the directional valve of a power pack, please order model VSM-21.  
(see picture on page 410).

## VSM Safety-check valves

### 700 bar

These safety-check valves are used for those applications where pressure drops must be avoided (e.g. holding of a lifted load). Depending on the location in a hydraulic circuit, these valves can have different functions.

The model VSM-11 can be directly screwed into the oil port of a hydraulic cylinder and works at this location as a "hose break fuse". The design of the VSM-21 is suitable for a combination with VHP directional valves.

At this location the VSM-21 ensures that the pressure is held precisely and that pressure drops caused by operating the directional valve are avoided.

### Operation

After closing the relief valve (hand wheel) the cylinder can be advanced via the by-pass. In direction to the cylinder the valves always have free flow. The built-in check valve ensures that a pressurized cylinder (e.g. a lifted load) is held precisely in stop position.

A smooth lowering speed can be adjusted by opening the throttle valve (hand wheel) in order to relieve the pressure. A safety pressure valve protects the cylinder from being overloaded by external loading.

### Technical data VSM

Model	Art.-No.	Operating pressure max. bar	Control	Oil-port cylinder side A	Oil-port pump side B	Width mm	Weight kg
VSM-11	N14100921	700	Check valve	3/8-18 NPT outer	3/8-18 NPT inner	6	0.9
VSM-21	N14100972	700	Check valve	3/8-18 NPT inner	3/8-18 NPT outer	6	1.0

### Dimensions VSM (housing incl. hand wheel)

Model	VSM-11	VSM-21
Length, mm	65	65
Width, mm	60	60
Height, mm	110	110

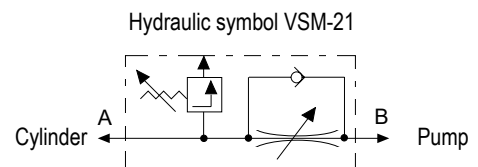

## VHM Throttle-/Shut-off valves

700 bar

These valves are used to shut-off hydraulic lines especially in multiple cylinder systems. The needle valve VHM-1 also allows to throttle an oil flow especially in connection with lifting applications.



VHM-1-E



VHM-2

### Technical data VHM

Model	Art.-No.	Operating pressure max. bar	Control	Oil ports both ends	Width mm	Weight kg
VHM-1-E	N14101313	700	Needle	3/8-NPT inner	4	0.7
VHM-2	N14100344	700	Ball	3/8-NPT inner	6	0.9

### Dimensions VHM

Model	VHM-1-E	VHM-2
Length, mm	70	75
Width, mm	30	45
Height, mm	80	75

Hydraulic symbol

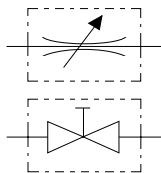

## VPS Pressure switch

Adjustable between 100 - 800 bar

As soon as the pressure has reached the set value, a micro-switch (altering contact) is activated.

This signal can be used:

- For automatic pressure limiting.
- To report a certain pressure value.
- As an automatic motor on/off switch with pressure guard power packs.



### Technical data VPS

Model	Art.-No.	Control range bar	Electric data	Oil ports	Difference of switch point bar	Repeat accuracy bar	Weight kg
VPS-1	N14100639	100 - 800	5 A/250 V	3/8 NPT	25 - 70	10	0.5

Hydraulic symbol

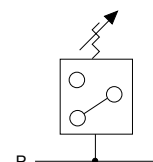

### Dimensions VPS

Model	VPS-1
Height x Width, mm	130 x 85

As soon as the pressure has reached the set value, a micro-switch (alternating contact) is activated. Should the pressure drop, the micro-switch starts the pump again in order to rebuild the pressure.





## VPR Pressure relief valves

### 0 - 700 bar

Pressure relief valves are used if the system pressure (force of the connected hydraulic cylinder) should not exceed a certain value. These precision valves can be easily adjusted and are characterized by precise repetition. The question of a pressure relief valve only depends on the displacement of the high pressure stage of the power pack.

After achieving the set pressure value, the excessive oil is guided back to the reservoir (pressureless).

### Technical data VPR

Model	Art.-No.	Control range bar	Oil ports P	Oil ports T	Oil flow max. l/min	Weight kg
VPR-1	N14100722	0 - 700	G 3/8	G 1/4	10	0.8

### Dimensions VPR

Model	VPR-1
Length, mm	120
Ø, mm	40

### Hydraulic symbol

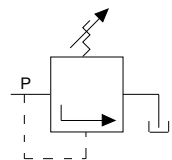

## MY Manifolds

### 700 bar

Manifolds are used when several hydraulic cylinders have to be connected to one hydraulic pump. All manifolds are equipped with 3/8 NPT inner oil ports, so that fittings, hydraulic hoses and couplers can easily be attached.

To connect a manifold directly to a hand pump a FY-1 double nipple is recommended.

Each manifold is supplied with three steel blind plugs in case not all the oil ports are required.



### Technical data MY

Model	Art.-No.	Oil ports	Weight kg
MY-1	N14100164	6 x 3/8-NPT inner	0.5
MY-2	N14100247	4 x 3/8-NPT inner	0.6
MY-4	N14100198	7 x 3/8-NPT inner	1.4

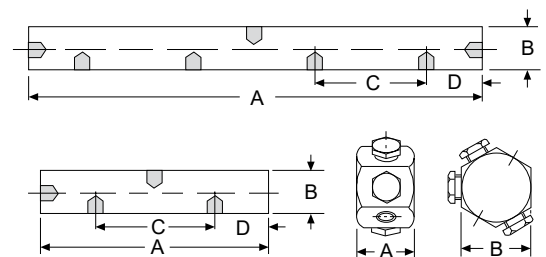

### Dimensions MY

Model	MY-1	MY-2	MY-4
A, mm	40	150	330
B, mm	50	40	40
C, mm	-	90	90
D, mm	-	30	30



## MY Manifolds

### With shut-off valves, 700 bar

Manifolds with shut-off valves are used when different pressures must be maintained in each hydraulic line and therefore allow the lifting of unequal loads. The manifolds are fully assembled and can be screwed directly to a hand pump or power pack. Depending on the way of assembly a short hose HHC-10 and a coupler half CFY-1 can be helpful.

Manifolds models MY ... GYA are equipped with the corresponding number of shut-off valves plus pressure gauge sets (GYA-63) which allow a permanent reading of each individual load.

### Technical data MY

Model	Art.-No.	Version	Weight kg
MY-22	N14100503	2-way manifold with 2 shut-off valves	1.8
MY-44	N14100504	4-way manifold with 4 shut-off valves	3.7
MY-66	N14101056	6-way manifold with 6 shut-off valves	5.5
MY-22-GYA	N14101024	2-way manifold with 2 shut-off valves and 2 pressure gauges	2.8
MY-44-GYA	N14101025	4-way manifold with 4 shut-off valves and 4 pressure gauges	5.7
MY-66-GYA	N14101057	6-way manifold with 6 shut-off valves and 6 pressure gauges	8.5

Assembly examples:



Hand pump  
HPS-2/2 A with MY-44



Electric hydraulic pump  
PY-07/3/20/3 M with VSM-21 and MY-44

## HPK-10 Transportation box

### For hand pumps, hydraulic cylinders and accessories

For easy transportation and protection of your valuable tools. Large enough to take a hand pump with pressure gauge and hydraulic hose plus several hydraulic cylinders.

The sturdy sheet metal box is equipped with a solid handle and two clasps.

#### HPK-10

Dimensions (L x W x H): 800 x 300 x 170 mm,  
Weight: approx. 7.8 kg.



## HFY Hydraulic oil

### For all hand pumps and power packs

The high quality of the Yale hydraulic oil guarantees a long service life for your equipment.

The high grade HLP oil comes as follows:

#### Features

- Class of viscosity ISO VG 32.
- High lubrication index.
- High pressure resistance
- Favourable temperature/viscosity index.
- Protection against corrosion and cavitation.
- Minimizes the formation of foam and sludge.
- Good derivation of temperature.
- No aging problems
- Good compatibility with all sealing materials.
- Fulfills all requirements of DIN 51524 part 2.



#### Technical data HFY

Model	Art.-No.	Content l
HFY-1	N14300194	1
HFY-5	N14300195	5
HFY-10	N14301061	10
HFY-20	N14301062	20



## GGY Pressure gauges

The use of pressure gauges is recommended when the operating pressure (the force of the connected cylinder) should be monitored. Yale pressure gauges are equipped with a stainless steel housing and an acrylic plastic face cover plate.

To absorb pressure shocks gauges are glycerine-filled, thus contributing to a long service life. Also, when fitted to a motor pump, the pointer will stay jitterfree.

For the calculation of applied cylinder forces corresponding converting charts (pressure vs. force) can be supplied for all Yale hydraulic cylinders free of charge.

### Technical data GGY

Model	Art.-No.	Pressure range bar	Scale diameter mm	Glycerine- damped	Oil port DIN 16288	Spanner size	Accuracy class %
GGY-631	N14100168	0 - 1000	63	yes	G 1/4	14	1.6
GGY-632	N14100663	0 - 1000	63	yes	1/4 NPT	14	1.6
GGY-633	N14100877	0 - 160	63	yes	G 1/4	14	1.6
GGY-634	N14100878	0 - 250	63	yes	G 1/4	14	1.6
GGY-635	N14100879	0 - 400	63	yes	G 1/4	14	1.6
GGY-636	N14100880	0 - 600	63	yes	G 1/4	14	1.6
GGY-1001	N14100169	0 - 1000	100	yes	G 1/2	22	1.0
GGY-1001 SZ <sup>1</sup>	N14100698	0 - 1000	100	yes	G 1/2	22	1.0
GGY-1002	N14100664	0 - 250	100	yes	G 1/2	22	1.0
GGY-1003	N14100696	0 - 400	100	yes	G 1/2	22	1.0
GGY-1004	N14100697	0 - 700	100	yes	G 1/2	22	1.0
GGY-1005	N14101023	0 - 160	100	yes	G 1/2	22	1.0
GGY-2500	N14100658	0 - 2500	100	yes	G 1/2	22	1.6

<sup>1</sup>GGY-1001 SZ = with maximum pointer



## GYA-63 Pressure gauge set

Consisting of pressure gauge GGY-632 (diameter Ø 63 mm, glycerine-damped) and corresponding gauge adaptor. This pressure gauge set is suitable for connection to all HPS hand pumps.

Assembled ready to use, compact design with 45° inclination for easy reading.

### Technical data GYA-63

Model	Art.-No.	Pressure gauge bar	Oil port pump	Oil port hose	Weight kg
GYA-63	N14200497	0 - 1000 bar, Ø 63 mm, glycerine-damped	3/8-NPT outer	3/8-NPT inner	0.5

## GA Pressure gauge adaptor

Gauge connection with sleeve nut and 30° inclination for easy reading.

Suitable for all hand pumps series HPS.



### Technical data GA

Model	Art.-No.	Oil port gauge	Oil port pump	Oil port hose
GA-700	N14200201	G 1/4	3/8-NPT outer	3/8-NPT inner
GA-701	N14200208	G 1/2	3/8-NPT inner	3/8-NPT inner

## GA Pressure gauge adaptor set

For double-acting hand pumps model HPH, for mounting between 4/3-directional valve and hand pump.

### Features

- Advantage: shows both the pushing force and the pulling force of the connected hydraulic cylinder.
- 30° inclination for easy reading.
- Pressureless return line by means of telescopic double nipple.



### Technical data GA

Model	Art.-No.	Oil port gauge	Oil port	Telescopic nipple
GA-703	N14200202	G 1/2	2 x 3/8-NPT outer	2 x 1/4-NPT outer
GA-704	N14200640	G 1/4	2 x 3/8-NPT outer	2 x 1/4-NPT outer

## GA-2000 Pressure gauge adaptor

This pressure gauge adaptor is suitable for connection to all TWAZ hand pumps (2000 bar). Suitable for pressure gauge GGY-2500.



### Technical data GA-2000

Model	Art.-No.	Operating pressure max. bar	Oil port gauge	Oil port pump	Oil port hose
GA-2000	N14200419	2.000	G 1/2	M22 x 1.5 outer (with seal cone)	M22 x 1.5 inner (for FY - 201)



## CFY, CMY, CCY Hydraulic couplers

Yale hydraulic couplers are self-sealing which means that the coupler halves only have to be closed hand-tight. Both female and male parts have inner balls which seal the coupler halves in uncoupled condition, so that no hydraulic fluid will leak.

Please note that all Yale hydraulic cylinders are equipped with the standard female coupler half CFY-1 and dust cap CDF-9.

### Technical data CFY, CMY and CCY

Model	Art.-No.	Description	Oil port thread	Pressure max. bar
CFY-1	N14200166	Coupler half, female (standard)	3/8-NPT, outer	700
CFY-2	N14200482	Coupler half, female	3/8-NPT inner	700
CFY-18	N14200420	Coupler half, female	M18 x 1.5 outer	700
CFY-10-S	N14200814	Coupler half, female	Pipe Ø 10 mm	700
CMY-1	N14200167	Coupler half, male	3/8-NPT, inner	700
CCY-1	N14200165	Coupler halves, female + male	3/8-NPT	700
CDF-9 <sup>1</sup>	N14200396	Dust cap, rubber	-	-

<sup>1</sup>fits to female and male coupler halves (standard with all female coupler halves)

### Dimensions CFY, CMY and CCY

Model	CFY-1	CFY-2	CFY-18	CFY-10-S	CMY-1	CCY-1
A, mm	-	-	-	-	-	87
B, mm	72	78	72	72	-	-
C, mm	-	-	-	-	40	-
D, mm	35	35	35	35	-	-
E, mm	14	27	24	24	-	-
F, mm	-	-	-	-	32	-

## INFO

Hydraulic couplers must always be completely closed, since otherwise the circulation cannot be released.

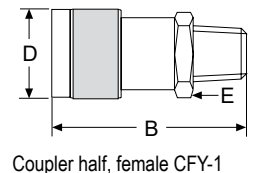
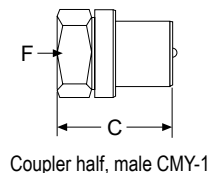
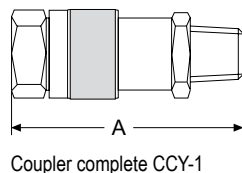

## HHC Hydraulic hoses

Durable but highly flexible thermoplast hydraulic hoses guarantee a very long life.

The 4-layer build-up includes 2 layers of high tensile steel fabric and robust fitting with 19mm hexagon.

The volumetric expansion is very low. Hydraulic hoses model HHC are equipped with a male coupler half as standard.

Standard length are as per the chart below, further lengths or hoses with larger diameters are quoted on request.



### Technical data HHC

Model	Art.-No.	Length m	Operating pressure bar	Burst pressure bar	Connection 2 male coupler half CMY-1	Connection 1 thread nipple 3/8-NPT, outer	External diameter approx. mm	Bend radius min. mm	Width mm
HHC-5	N14200330	0.5	700	2.800			14	100	6.3
HHC-10	N14200300	1	700	2.800			14	100	6.3
HHC-20	N14200151	2	700	2.800			14	100	6.3
HHC-30	N14200331	3	700	2.800			14	100	6.3
HHC-40	N14200152	4	700	2.800			14	100	6.3
HHC-60	N14200209	6	700	2.800			14	100	6.3
HHC-80	N14200313	8	700	2.800			14	100	6.3
HHC-100	N14200332	10	700	2.800			14	100	6.3
HHC-120	N14200702	12	700	2.800			14	100	6.3
HHC-150	N14200703	15	700	2.800			14	100	6.3

### How to order

#### Hydraulic hose for all standard combinations (- pump - hose - cylinder -):

Order a standard hose with female coupler half HHC-... (e.g. HHC-20).

#### Hydraulic hose for coupling connections on both sides (both ends with CMY-1):

Order a complete coupler CCY-1 in addition to a standard hose HHC-... (recommended for long hydraulic hoses).

#### Hydraulic extension hose

(one male coupler half, one female coupler half):

Order a female coupler half CFY-2 (inner thread) in addition to a standard hose model HHC-...

#### Hydraulic hose without any coupler parts (both ends with threaded nipples):

Order model HH-... (both ends 3/8-NPT outer).













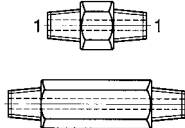

## FY Fittings, reducers, connectors

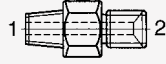

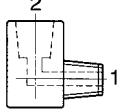



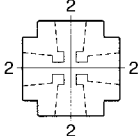

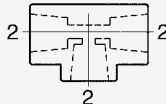

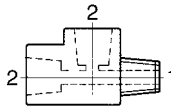

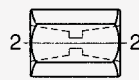

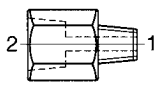

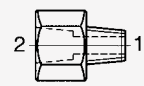
Fittings are useful for versatile combinations of hydraulic cylinders.

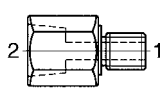
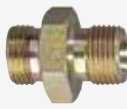
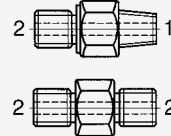
Yale high pressure fittings have been designed to give a variety of connections, extensions and combinations. The fittings are designed for a max. system pressure of 700 bar.

For improved sealing of 3/8 NPT connections use two layers of teflon tape and tighten accordingly.

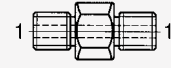
### Technical data FY

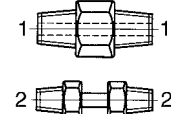
Model	Art.-No.		Description	Figures	Connection 1	Connection 2
FY-1 FY-1L	N14200153 N14200659		Double nipple Double nipple, long		3/8 NPT outer 3/8 NPT outer	– –
FY-13 FY-17 FY-18	N14200244 N14200342 N14200343		Double nipple		1/4 NPT outer 3/8 NPT outer 3/8 NPT outer	R 1/4 outer M14 x 1.5 (for sleeve nut) R 1/4 outer
FY-2	N14200154		Elbow		3/8 NPT outer	3/8 NPT inner
FY-3	N14200155		Elbow		–	3/8 NPT inner
FY-6	N14200158		Cross		–	3/8 NPT inner
FY-4	N14200156		Tee		–	3/8 NPT inner

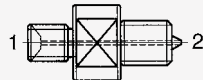
Model	Art.-No.		Description	Figures	Connection 1	Connection 2
FY-5	N14200157		Tee		3/8 NPT outer	3/8 NPT inner
FY-7 FY-11	N14200159 N14200243		Connection		-	3/8 NPT inner 1/4 NPT inner
FY-8 FY-9	N14200199 N14200224		Adaptor		3/8 NPT outer 1/4 NPT outer	R 1/2 inner 3/8 NPT inner
FY-10 FY-12	N14200245 N14200246		Adaptor		3/8 NPT outer 1/2 NPT outer	1/4 NPT inner 3/8 NPT inner
FY-16 FY-19 FY-20 FY-30 FY-33	N14200323 N14200353 N14200354 N14200693 N14200889		Adaptor		3/8 NPT outer M18 x 1.5 outer M14 outer G 3/8 outer 3/8 NPT outer	M18 x 1.5 inner 3/8 NPT inner 3/8 NPT inner 3/8 NPT inner M14 x 1.5 inner
FY-26 FY-27	N14200654 N14200655		Double nipple		3/8 NPT outer G 3/8 outer	G 3/8 outer G 3/8 outer
FY-31 FY-32	N14200694 N14200695		Connection		3/8 NPT inner 3/8 NPT inner	M18 x 1.5 inner M20 x 1.5 inner
FY-35	N14200890		Double nipple		M 14 outer	-
FY-703	N14200203		Connecting set for 4/3-way valve to HPS hand pumps (telescopic nipple)		3/8 NPT outer	1/4 NPT outer
FY-201	N14200487		Adaptor for TWAZ hand pumps 2000 bar		R1/4 outer	M22 x 1.5 outer (with seal cone)



## BMZ Hydraulic puller with integrated hydraulics

### Pulling force max. 6, 8 and 11 t

Hydraulic pullers are a valuable tool for the maintenance engineer. The pullers allow time and cost savings as they offer high working safety and can be operated in all positions. Hydraulic pullers are used in all kinds of industries, workshops and in many repair and assembly jobs to remove or install interference fit parts, such as: gears, couplings, bearings, wheels, pulleys, axles, shafts, break drums and many other press fit components. Damage to parts is minimized through the use of controlled hydraulic power, whilst machine down-time can be reduced drastically.

### Features

- Drop-forged alloy steel jaws.
- Hard chromium plated piston, spring return.
- No radial moment of torsion.
- No spindle wear.
- Integrated hydraulic cylinder and pump.
- Quick adjustment with trapezoid speed nut.
- 3 and 2-jaw design.
- Pump lever can rotate through 360°.
- Piston with durable, spring loaded centering tip.
- Supplied in a sturdy plastic box.

### Technical data BMZ

Model	Art.-No.	Pulling force max. t	Stroke mm	Weight kg
BMZ-6	N13500610	6	82	4.9
BMZ-8	N13500611	8	82	6.6
BMZ-11	N13500612	11	82	8.0

### Dimensions BMZ

Model	BMZ-6	BMZ-8	BMZ-11
Reach max. A, mm	160	200	230
Width Ø max. B, mm	200	250	280
Length C, mm	320	320	345

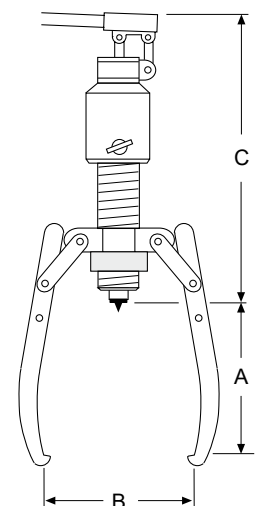



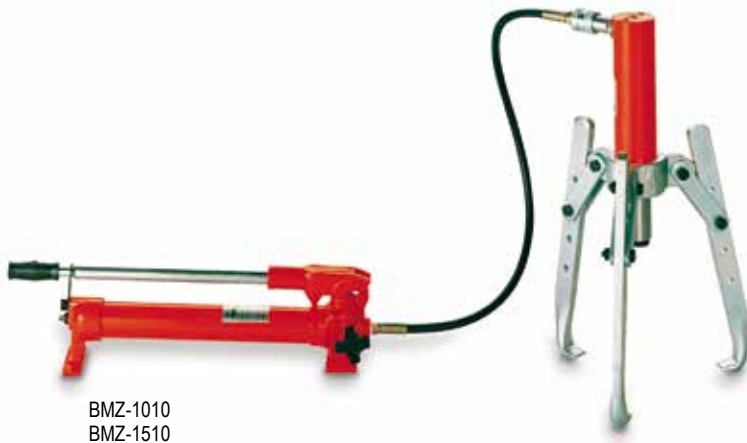

BMZ-1010  
BMZ-1510



BMZ-2311

## BMZ Puller sets with separate hydraulics 10, 15 and 23 t

### Pulling force max. 10 - 23 t

The harder the pulling force, the tighter the grip of the jaws. Longer jaws up to 1000 mm are available on request.

### Features

- High quality components from our standard hydraulic programme.
- Modular system, hydraulic parts can also be used for many other applications.
- Long-life hydraulic cylinders manufactured from chromium-molybdenum steel.
- Two-stage quick-action hand pumps.
- Incl. high pressure hydraulic hose with quick coupler, L = 2.0 m.
- All complete sets are supplied in metal box HPK-10 or wooden case.
- All sets are supplied ready to use.

### Scope of delivery:

- Pressure gauge set GYA-63.



Accessories for BMZ-2300 and BMZ-2311: BMZ-2308 extensions of pulling arms increase the reach (A) up to 395 mm. BMZ-2309 up to 495 mm.



Pressure gauge set GYA-63 is part of the scope of delivery.

## BMZ-1010 and 1510

The harder the pulling force, the tighter the grip of the jaws. Longer jaws up to 1000 mm are available on request.

## BMZ-2311

The radially adjustable pulling arms can be locked in any position.

## Technical data BMZ

Model	Art.-No.	Pulling force max. t	Hydraulic cylinder model	Hand pump model	Hydraulic hose model	Stroke of the cylinder mm	Weight kg
BMZ-1000	N13500613	10	without	without	without	-	9.5
BMZ-1010	N13500614	10	with YS-10/150	with HPS-2/0,7 A	HHC-20	150	21.5
BMZ-1500	N13500615	15	without	without	without	-	9.5
BMZ-1510	N13500616	15	with YS-15/150	with HPS-2/0,7 A	HHC-20	150	23.5
BMZ-2300	N13500617	23	without	without	without	-	56.8
BMZ-2311	N13500600	23	with YS-23/160	with HPS-2/0,7 A	HHC-20	160	106.0

## Dimensions BMZ

Model	BMZ-1000	BMZ-1500	BMZ-2300
Reach max. A, mm	300	300	190
Width Ø max. B, mm	350	350	700

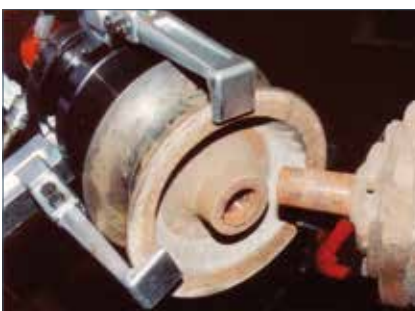
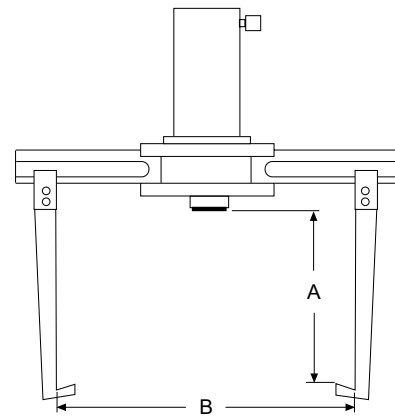
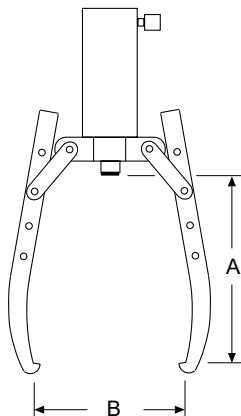

## YHP Hydraulic puller sets

### Pulling force max. 10 - 50 t

These professional puller sets are designed for removing and installing press-fitted or heat-fitted parts.

Hydraulic puller sets eliminate time-consuming and costly repairs as they avoid the damage of parts and reduce machine downtimes. All parts are manufactured from high quality drop-forged steel.

### Scope of delivery

The complete sets are supplied ready to use and include all necessary components such as hollow cylinder, hydraulic hand pump, pressure gauge (to control the pulling force) and 2 meter hydraulic hose with quick-connect coupler.

## INFO

The set "Cross-bearing puller" have reduced max. pulling forces.



### 3-Grip puller sets

For all pulling jobs where solid parts have to be removed, e.g. gears, belt pulleys, sprockets, flywheels, couplers, shafts, axles etc. The sets can be used as both 3-jaw and 2-jaw puller.

Model	Art.-No.	Pulling force max. t
YHP-252 G	N13500005	20
YHP-352 G	N13500006	30
YHP-552 G	N13500007	50



### Cross-bearing puller sets

For all pulling jobs where multi-segmented parts have to be removed: ball bearings, roller bearings and similar parts. Puller sets are supplied complete with bearing puller attachment and bearing cup puller.

Model	Art.-No.	Pulling force max. t
YHP-262 G	N13500008	10
YHP-362 G	N13500009	15
YHP-562 G	N13500010	25



### Multi-purpose puller sets

These multi-purpose puller sets are universal combinations of both a.m. sets and include all necessary parts from 3-grip puller set and crosshead puller set.

Model	Art.-No.	Pulling force max. t
YHP-2752 G	N13500011	20/10
YHP-3752 G	N13500012	30/15
YHP-5752 G	N13500013	50/25

## Type of puller set

Model	3-grip puller set			Crosshead puller set			Multi purpose puller set		
	YHP-252 G	YHP-352 G	YHP-552 G	YHP-262 G	YHP-362 G	YHP-562 G	YHP-2752 G	YHP-3752 G	YHP-5752 G
Art.-No.	N13500005	N13500006	N13500007	N13500008	N13500009	N13500010	N13500011	N13500012	N13500013
Nennkraft, t	20	30	50	10	20	25	20/10	30/15	50/25
Hand pump, model HPS-1/07 A (part 1)	•	•	–	•	•	–	•	•	–
Hand pump, model HPS-2/2 A (part 1)	–	–	•	–	–	•	–	–	•
Pressure gauge set, model GYA-63 (part 2)	•	•	•	•	•	•	•	•	•
Hydraulic hose, model HHC-20 (part 3)	•	•	•	•	•	•	•	•	•
Hollow cylinder (part 4), model	YCS-21/50	YCS-33/60	YCS-57/70	YCS-21/50	YCS-33/60	YCS-57/70	YCS-21/50	YCS-33/60	YCS-57/70
Triple crosshead (part 5)	•	•	•	–	–	–	•	•	•
Double crosshead (part 6)	•	•	•	–	–	–	•	•	•
Grip arm, 3 pcs. (part 8)	•	•	•	–	–	–	•	•	•
Spindle (part 9)	•	•	•	•	•	•	•	•	•
Strap, 6 pcs (part 10)	•	•	•	–	–	–	•	•	•
Strap screws + strap nuts, 6 pcs. (part 11)	•	•	•	–	–	–	•	•	•
Mounting screws, 2 pcs. (part 13a)	•	•	•	–	–	–	•	•	•
Mounting screws, 2 pcs. (part 13b)	–	–	–	•	•	•	•	•	•
Saddle with internal thread (part 14)	•	•	•	•	•	•	•	•	•
Smooth saddle (part 15)	•	•	•	•	•	•	•	•	•
Slotted crosshead (part 16)	–	–	–	•	•	•	•	•	•
Slide plate, 2 pcs. (part 17)	–	–	–	•	•	•	•	•	•
Nut, 2 pcs. (part 18)	–	–	–	•	•	•	•	•	•
Washer, 2 pcs. (part 19)	–	–	–	•	•	•	•	•	•
Pulling leg, short, 2 pcs. (part 20), mm	–	–	–	280	255	455	280	255	455
Pulling leg, long, 2 pcs. (part 21), mm	–	–	–	460	505	773	460	505	773
Leg end, 2 pcs. (part 24)	–	–	–	•	•	•	•	•	•
Leg connector, 2 pcs. (part 25)	–	–	–	•	•	•	•	•	•
Bearing puller attachment (part 26)	–	–	–	•	•	•	•	•	•
Bearing cup pulling attachment (part 27)	–	–	–	•	•	•	•	•	•
Storage case (part 29)	•	•	•	•	•	•	•	•	•
Weight, kg	40	65	120	46	86	156	91	172	295

The symbols stand for: • including complete set, – not included

## Dimensions hydraulic puller set YHP

Model	20 t	30 t	50 t
3-grip A, mm	300	520	700
C, mm	0 - 817	0 - 977	0 - 1233
3-grip B, mm	500	900	1200
D, mm	25 - 155	30 - 250	75 - 330
2-grip A, mm	300	520	700
E, mm	152	250	330
2-grip B, mm	420	700	1000
F, mm	140	150	150
G, mm	30 - 180	75 - 230	75 - 230

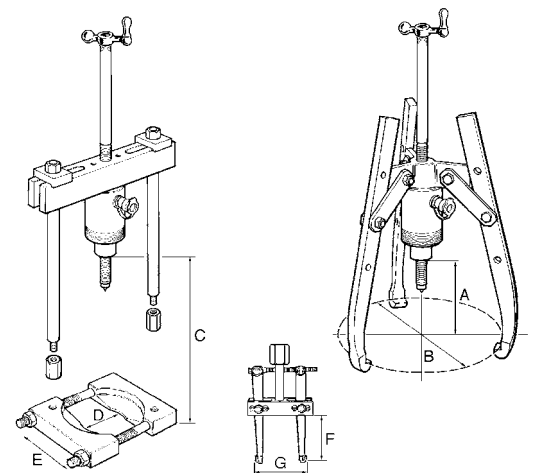





AJH-620

AJS-65

AJS-104

## AJH and AJS Aluminium hydraulic jacks

### Capacity 6.5 - 100 t

Aluminium jacks combine light weight with high lifting capacity. The use of high tensile aluminium alloy allows lifting capacities of up to 100 tons resulting in a very favourable 1.8 tons lifting capacity per 1 kg weight ratio. Operation of Yale hydraulic jacks is very simple. Jacks are supplied ready for use, i.e. including hydraulic oil, operating lever and, where applicable, carrying handle and lifting claw.

### Aluminium jacks with lifting claw

Jacks from 20 tons are available with a lifting claw. In this case the jacks are provided with an elongated base plate. The max. permissible working load of the lifting claws is 40 % of the jack capacity.

### Aluminium jacks with safety lock nut

Jacks from 20 tons can be supplied with a safety lock nut. This device allows absolute safe jacking over a long period. In this case the hydraulic jack can be operated like a mechanical support and the hydraulic system can be totally released.

### Application

Hydraulic jacks are universally popular tools for use in workshops or on site for all kinds of lifting and assembly applications, for construction, shipbuilding, power plants, general engineering, metal fabrication and many more. Applications are unlimited. Standard jacks with plain piston and jacks with safety lock nuts cannot be used with a lifting claw. To increase stability, all jacks with long stroke (305 mm) are equipped with an elongated base plate.

### Features

- Strokes from 75 - 305 mm.
- Extremely low weight.
- The 6.5 and 10 tons jacks can be operated in any position (also upside down) and are equipped with spring return piston and stop ring.
- The 20 to 100 tons jacks can be operated vertically or with front face in horizontal position.
- All jacks are provided with an overload protection valve.
- From 20 tons capacity with additional mechanical stroke limiter.
- All jacks with hardened alloy steel saddle and sensitive lowering valve which is activated by the operating lever.



AJH-630 SR

**Technical data AJH and AJS**

Model	Art.-No.	Capacity t	Capacity of lifting claw max. t	Stroke mm	Overall height mm	Base plate mm	Height of lifting claw min. mm	Weight kg
AJS-65	N13200950	6.5	–	75	131	159 x 76	–	3.6
AJS-104	N13200951	10	–	115	182	171 x 76	–	6.3
AJH-620	N13200952	20	–	152	265	180 x 120	–	10.9
AJH-1220	N13200955	20	–	305	440	250 x 120	–	16.7
AJH-630	N13200958	30	–	152	265	200 x 140	–	15.4
AJH-1230	N13200961	30	–	305	452	275 x 140	–	23.4
AJH-660	N13200964	60	–	152	293	250 x 190	–	27.4
AJH-1260	N13200967	60	–	305	500	340 x 190	–	43.7
AJH-6100	N13200970	100	–	152	315	305 x 250	–	49.0

**Jacks with lifting claw**

Model	Art.-No.	Capacity t	Capacity of lifting claw max. t	Stroke mm	Overall height mm	Base plate mm	Height of lifting claw min. mm	Weight kg
AJH-620 C	N13200953	20	8	152	280	250 x 120	67	14.5
AJH-1220 C	N13200956	20	8	305	452	250 x 120	67	22.2
AJH-630 C	N13200959	30	12	152	284	275 x 140	72	20.3
AJH-1230 C	N13200962	30	12	305	472	275 x 140	72	31.0
AJH-660 C	N13200965	60	24	152	327	340 x 190	72	43.1
AJH-1260 C	N13200968	60	24	305	533	340 x 190	72	64.9

**Jacks with safety lock nut**

Model	Art.-No.	Capacity t	Capacity of lifting claw max. t	Stroke mm	Overall height mm	Base plate mm	Height of lifting claw min. mm	Weight kg
AJH-620 SR	N13200954	20	–	152	291	180 x 120	–	10.9
AJH-1220 SR	N13200957	20	–	305	464	250 x 120	–	16.7
AJH-630 SR	N13200960	30	–	152	294	200 x 140	–	15.4
AJH-1230 SR	N13200963	30	–	305	480	275 x 140	–	23.4
AJH-660 SR	N13200966	60	–	152	330	250 x 190	–	27.4
AJH-1260 SR	N13200969	60	–	305	536	340 x 190	–	43.7
AJH-6100 SR	N13200971	100	–	152	366	305 x 250	–	53.0



## YAM Machine jacks with lifting claw

### Capacity 2 - 15t

Machine jacks with lifting claw are used in applications where space below the load is restricted, thus preventing the use of traditional lifting equipment.

Typical applications for machine jacks are lifting, positioning and transportation of machines, heavy steel constructions or similar loads, as well as general repair and assembly applications.

The jacks are also useful for applications like leveling of high-rise warehouses, heavy-duty scaffolds, large frameworks etc.

### Features

- Offers safe lifting of machines with an extremely low clearance.
- Incl. safety pressure valve to prevent overload.
- Large base offers increased stability under load.
- Pump lever can rotate through 270° (excluding YAM-2).
- Same load can be lifted on either the head or the claw of jack.
- Spring return of the lifting claw (only YAM-5 and YAM-10).
- Precision-adjustable lowering valve.
- Jacks are supplied ready to use incl. pump lever, and are filled with oil.

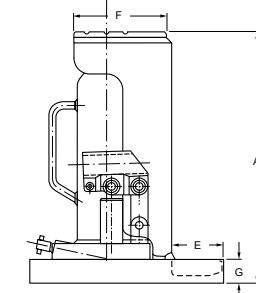
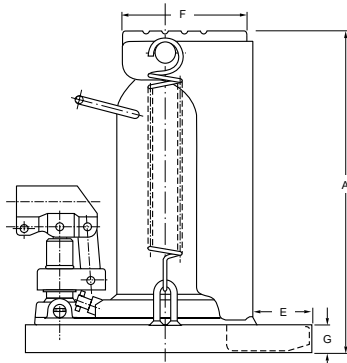
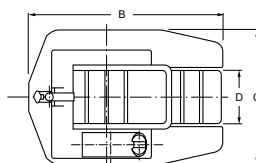
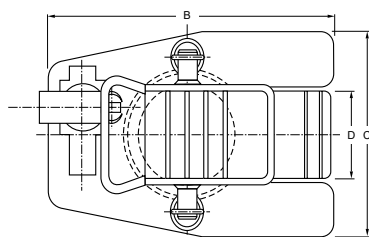

### Technical data YAM

Model	Art.-No.	Capacity on the claw t	Stroke mm	Weight kg
YAM-2	N13100912	2	113	8
YAM-5	N13100627	5	120	19
YAM-10	N13100628	10	145	38
YAM-15.1	N13100914	15	140	53

### Dimensions YAM

Model	YAM-2	YAM-5	YAM-10	YAM-15.1
A, mm	235	290	325	344
B, mm	180	257	280	321
C, mm	125	182	240	258
D, mm	50	75	100	110
E, mm	50	57	60	60
F, mm	85	117	150	168
G, mm	16	26	33	33

## YAP Hydraulic machine jacks

### Capacity 4.5 - 50 t

Hydraulic machine jacks are designed for the safe lifting and positioning of machines and similar heavy equipment.

#### Features

- These jacks are operated with external pumps, e.g. hand or motor pumps but also with synchronous power packs.
- The compact construction allows operation even in extremely confined areas.
- 3 hook-in positions of the lifting claw provide high flexibility (model YAP-5130 4 hook-in positions).
- The load can be lifted with either the lifting claw or with the head of the jack.
- Welded, distortion-proof steel construction.
- High quality, durable hydraulic components.
- The flat lifting claw allows low jacking height.
- Safe stability due to swivel-mounted support feet.
- The connection between jack and pump is made by a hydraulic hose.
- The jacks are delivered ready-to-use inclusive of carrying handles and coupling half.



#### Technical data YAP

Model	Art.-No.	Capacity t	Stroke mm	Height for applications min. mm	Pressure max. bar	Weight approx. kg
YAP-5130	N13101114	4.5	133	15	700	13.5
YAP-10150	N13101115	10	155	20	700	23.0
YAP-15150	N13101116	15	155	25	700	40.0
YAP-25150	N13101117	23	155	30	700	60.0
YAP-50150	N13101118	50	155	35	700	165.0

#### Dimensions YAP

Model	YAP-5130	YAP-10150	YAP-15150	YAP-25150	YAP-50150
A min., mm	15	20	25	30	35
A max., mm	232	273	291	300	375
B, mm	228	277	328	387	540
H, mm	252	283	316	330	405
L, mm	161	194	245	278	375

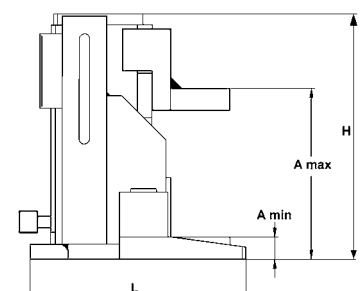
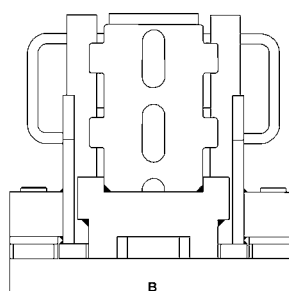

## YAS Hydraulic machine jacks

### Capacity 3 - 25t

Hydraulic machine jacks are designed for the safe lifting and positioning of machines and similar heavy equipment.

#### Features

- Integrated hydraulic pump.
- Pump lever swivel mounted 270° for operation even in extremely confined areas.
- Same load can be lifted on either the head or the claw of jack.
- Welded, distortion-proof steel construction.
- High quality, durable hydraulic components.
- The flat lifting claw allows low jacking height.
- The additional connect coupler (10 t capacity and larger) for external pump operation, allows connection of hand, motor or synchronous lifting pumps (max. pressure 520 bar).
- Safe stability due to swivel-mounted support feet.
- Sensitive lowering valve for slow lowering of loads without jerks.
- When operating the jack with an external pump the installation of a manometer is mandatory.
- The integrated hydraulic pump is protected by a pressure-limiting valve.
- The jacks are delivered ready-to-use inclusive of carrying handles, hydraulic oil filling and pump lever.
- YAS-15 and YAS-25 with twin pump for higher lifting speed as well as wheels for easy transportation.



### Technical data YAS

Model	Art.-No.	Capacity t	Stroke mm	Height for applications min. mm	Pressure max. bar	Weight approx. kg
YAS-3	N13101119	3	140	12	520	15.0
YAS-5	N13101120	5	140	15	520	19.0
YAS-10	N13101121	10	140	20	520	28.0
YAS-15	N13101122	15	140	25	520	50.0
YAS-25	N13101123	25	140	30	520	72.0

### Dimensions YAS

Model	YAS-3	YAS-5	YAS-10	YAS-15	YAS-25
A min., mm	12	15	20	25	30
A max., mm	230	232	300	291	300
B, mm	207	228	277	328	387
H, mm	250	252	252	316	330
L, mm	198	216	271	345	388

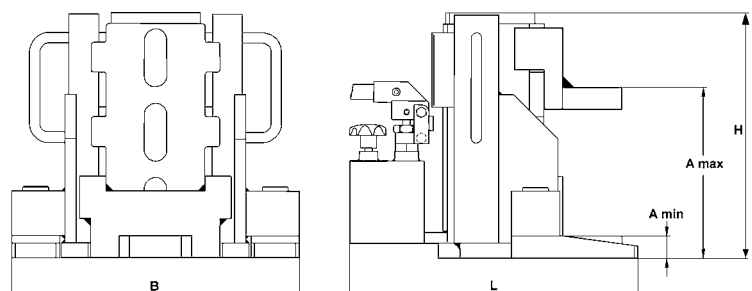

## ST Hydraulic stage lifts

### Capacity 50 - 100 t

For compact, low-headroom and universal applications. Stage lifts are hydraulic lifting devices which are designed to lift and lower loads over high distances.

Stage lifts overcome the usual limitations of their lifting height imposed by stroke length. Stage lifts operate with "double-acting" hydraulic cylinders (return stroke by hydraulic pressure) and are equipped with a load spreading plate and a piston support plate.

### Operation

A stage lift operates inverted and lifts the load via the bottom of the cylinder whilst it climbs on a pile of support bars (wood or aluminium). In principle, the load can be lifted to any height although stage lifts are still compact and versatile for low-headroom lifting applications.

The simple "3-step operation" eliminates the need for additional holding arrangements and the repositioning or replacing of cylinders which are normally required for a higher lifting distance. A stage lift climbs up and down on its own.

### Control

Depending on the power pack, selected stage lifts can be controlled individually (by hand or motor pump) or together in a synchronized arrangement with multi-flow pumps.

### Features

- Yale ChroMo-Design.
- Low-cost lifting systems possible, (3-point resp. 4-point).
- Low weight (e.g. 60 kg for a 50 t unit).
- Stage lift body made from high-grade aluminium.
- Hydraulic cylinders are made from robust chromium-molybdenum steel with double bronze bearings ensure a longlife service system.
- Large-diameter tilt saddle.
- Incl. coupler halves, non-interchangeable on request.



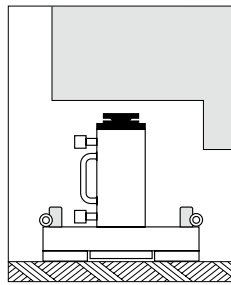

1. Stage: Initial position, stage lift rests on the ground under the load.

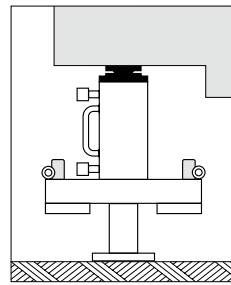

2. Stage: Step 1, load is raised.

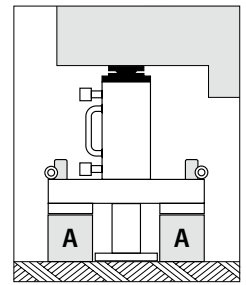

3. Stage: Two support bars type "A" are positioned in place.

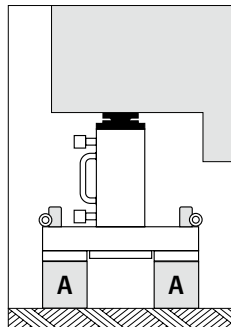

4. Stage: Piston is retracted and load rests on support bars type "A".

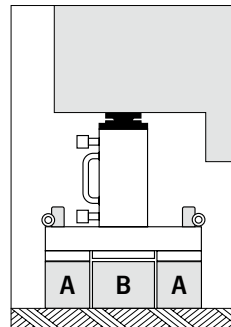

5. Stage: Broader middle bar type "B" is inserted.

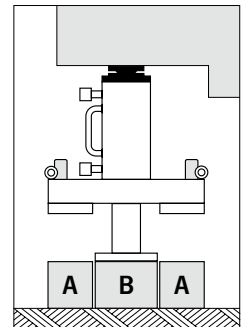

6. Stage: Step 2, load raised on broader middle bar "B".

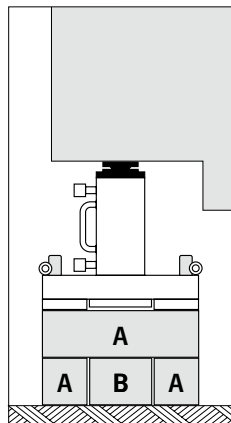

7. Stage: Two bars "A" are inserted and rotated at 90°, piston is retracted and middle bar is inserted.

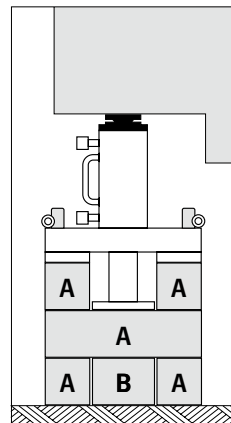

8. Stage: Load is lifted on middle bar (3rd step), two support bars type "A" are positioned at 90° and load rests on support bars "A".

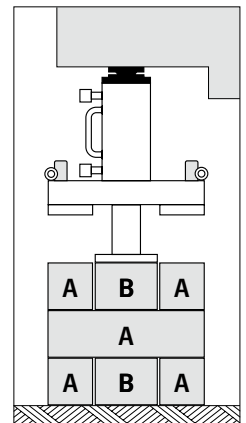

9. Stage: Piston is retracted, middle bar type "B" is inserted and lifts the 4th step on middle bar "B" and so on...

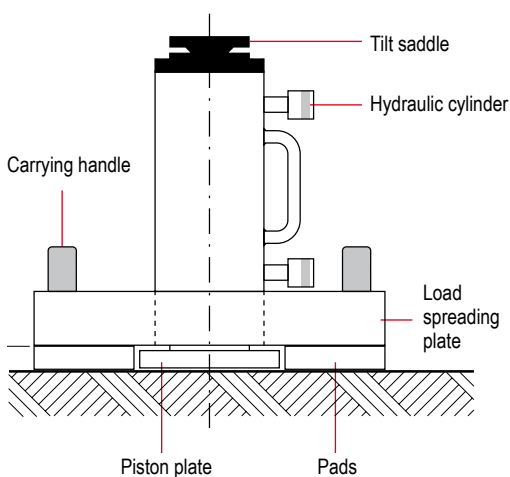

## Technical data ST

Model	Art.-No.	Capacity max. t	Stroke mm	Overall height mm	Load-spreading plate Ø mm	Piston plate Ø mm	Weight approx. kg
ST-5015	N15000923	50	150	396	425 x 425	160	60
ST-10015	-	100	150	455	525 x 525	180	115

## YHS Hydraulic spreader

### Capacity max. 0.5 - 1.5 t

These universal power tools can be used for all repair, maintenance and assembly work requiring precisely controlled power, e.g. aligning of containers and shells, lifting, positioning or aligning of machinery and structural components, forcing-off of shutterings and moulds. Applications are unlimited.

The spreaders can be operated with all hand pumps.

### Features

- Operating pressure max. 700 bar.
- Single-acting with spring return.
- Works in all positions.
- Spreader arms of high-tensile steel.
- Incl. female coupler half CFY-1 with dust cap.



### Technical data YHS

Model	Art.-No.	Capacity max. kN	Capacity max. t	Operating pressure max. bar	Oil volume max. cm <sup>3</sup>	Spread width min. mm	Spread width max. mm	Weight kg
YHS-05	N13400910	5	0.5	700	10	16	75	1.9
YHS-10 A	192098210	10	1.0	700	10	10	94	2.3
YHS-15	N13900609	15	1.5	700	70	35	220	6.9

## YCC-201 Hydraulic chain cutter

This hydraulic chain cutter has been designed for cutting high-tensile, grade 10 chains up to a material diameter of 13 mm. The open design allows easy positioning of the chain. The unit can be operated using the standard hand or motor pumps.

Recommended pump:

Electric power pack PY-04/2/5/2M

### Features

- Cutting performance:
  - max. material dimension grade 10 Ø: 13 mm
  - max. cutting force: 23 t
  - Weight: 37.4 kg
- Solid, stable and rigid body
- Built-in standard hydraulic cylinder, single-acting with spring return
- Both through-hardened cutting blades are identical in construction, can be re-sharpened and are easy to remove.
- Protection flap with acrylic glass pane allows safe monitoring of cutting process
- Opening in base plate allows chips and splinters to fall down through the body for removal
- Special chain support device for cutting larger chains







## RPYS-1215 Hydraulic test rig for hoisting equipment

### Capacity max. 12 t

For testing pul-lifts, lever hoists, chain blocks, wire rope pullers as well as other lifting equipment after repair or inspection.

### Testing of hoisting equipment

The lifting unit is placed between upper and lower shackle, the chain is tensioned against the oil cushion of the partly advanced piston of the hydraulic cylinder.

The applied force can be read at the pressure gauge.

### Testing of the hoist brake

For a functional test of the hoist brake the hand pump may be used to apply a counter pressure and thus increase the pulling force after a general test.

### Frequent use

For frequent testing, the hand pump may be replaced by a low-cost air hydraulic (model PAY-6) or electric pump (model PY-04/2/5/2 M).

### Pressure gauge

To read pulling forces more easily, the test rig is equipped with two high-quality pressure gauges.

Quick couplers allow an easy replacement of pressure gauges.

Pressure gauge 1 for small test items: GGY-1005, display: 0 - 160 bar, Ø 100 mm, Kl. 1.0 %

Pressure gauge 2 for big test items: GGY-1003, display: 0 - 400 bar, Ø 100 mm, Kl. 1.0 %



Permanent load lifting magnet TPM 0,3 for a test in the test rig RPYS-1215 complete with the test plate AYP-1215-S



## AYP-1215-S Test plate for permanent load lifting magnets

### Test load max. 12 t

For testing of permanent load lifting magnets according to DIN EN 13155.

The plate is placed into the 12 ton test rig RPYS-1215 (or other versions of this test rig) and connected to the frame with a bolt.

The test plate with a standardised surface according to DIN EN 13155 kann be adjusted horizontally to align it steadily.

Dimensions: 800 x 490 x 60 mm

**Features**

- Fully welded, low-strain press-frame.
- Upper and lower suspension hook by means of shackles, incl. two 5 tons pull-rings for smaller test units.
- Lateral pump table.
- Infinite adjustment of the pulling force.
- Chart for easy determination of test force.
- Removable lower suspension e.g. for testing of plate clamps.
- Base pre-drilled for mounting.
- High-quality hydraulic components.
- YCS-21/150 hollow cylinder made from chromium-molybdenum steel, heat-treated and hard chromium-plated. Long cylinder stroke of 150 mm with bronze bearings.
- Two-stage quick action hand pump HPS-2/0,7A.
- High-strength threaded bar M27.
- Fine-adjustment pressure valve.

**Technical data RPYS**

Model	Art.-No.
RPYS-1215	N13700895

**Dimensions RPYS**

Model	RPYS-1215
A, mm	2580 - 2730
B, mm	2160
C, mm	1840
D, mm	500
E, mm	630
F, mm	760
G <sup>1</sup> , mm	1030 - 1425
H, mm	750
J, mm	150
Weight, kg	225

<sup>1</sup>700 mm with 5t pull-rings

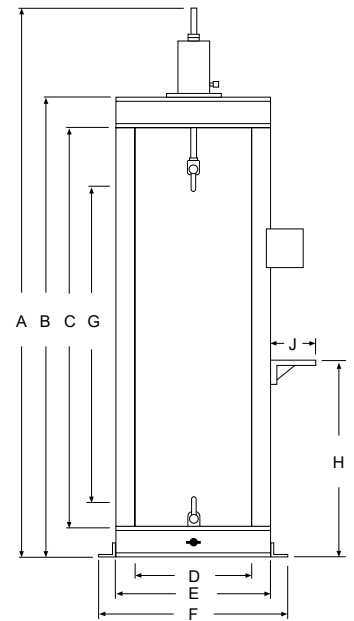

**INFO**

The test rigs are delivered complete and ready to use.



**RPYS-1535  
Hydraulic test rig  
for steel winches**

**Capacity max. 15 t**

For the testing of steel winches or similar lifting devices we offer a specific test rig.

**Features**

- Max. capacity 15 t.
- With hydraulic cylinder YS-15/350.
- Stroke: 350 mm.

**Scope of delivery**

- Incl. two-stage hand pump HPS-2/2 A.
- Fine-adjustment pressure valve 0 - 700 bar.
- Hydraulic hose 2 m, HHC-20.
- Pressure gauge: GGY-1004, display: 0 - 700 bar, Ø 100 mm, Kl. 1.0 %.



RPY-10 ... (10 t press)  
RPY-23 ... (23 t press)

## RPY and RPES Universal workshop presses

### Capacity 10 - 200 t

For all repair and assembly jobs.

According to European standards, all Yale workshop presses can be used without any additional protection devices as the piston speed is below 10 mm/s.

For special applications additional safety equipment (e.g. protection grid or two-hand-safety-control) can be offered on request.

### Applications

- Pressing and removing of bolts, shafts, bearings.
- Straightening of beams, profiles, axles, shafts.
- Forming, bending, crimping.
- General load tests and tests of weld specimens.
- Stamping, cutting, punching.
- Pre-adjustment of tools.

## Equipment of all presses

### Features

- All workshop presses are ready to use, including hydraulic oil, oil level gauge.
- High pressure-hydraulic hoses.
- Glycerine-damped pressure gauges.
- Fixing holes in base profiles, adjusting device for press table and head, swivelling pump console, conversion chart: Pressure-force etc.

## Description of the hydraulic cylinders

### Features

- Cylinders made from chromium-molybdenum steel, heat-treated and with metric mounting threads in the piston.
- Double bronze bearing of the hard chromium-plated piston.
- Piston return through spring or hydraulically.
- Mounting thread in the piston.
- Available piston strokes from 150 up to 500 mm.

## Description of the press-frames

### Features

- Robust, torsion-resistant construction.
- Solid, precision-welded press-frames.
- Open construction, easily accessible from all sides.
- 50 and 100 tons workshop presses with adjustable press table and press head (frames for adjustments are part of the delivery package).
- 200 t press with adjustable table and fix welded press head.
- Four locking bolts ensure a precisely aligned press head and press table and increase the stability of the frame (50 and 100 t).
- 50, 100 and 200 t presses with pivoting pump table with peripheral passage for straightening of exceptionally long parts.
- Modular system: Large variety of combinations of hydraulic cylinders and pumps possible.
- Drive either by hand or electric hydraulic pumps.



RPY-50 ... (50 t press)  
RPY-100 ... (100 t press)

## INFO

The press head of the 200 t model is fix welded to the press-frame.

Workshop presses are delivered ready to use.

## Description of the hand pumps

### Features

- All hand pumps with two-stage displacement.
- Glycerine-damped pressure gauge, Ø 63 mm, class 1.6 %.
- Hydraulic hose, L = 2.0 m with male coupler half.

## Description of the hydraulic power packs

### Features

- Longlife radial piston pumps, from 50 t with two-stage displacement.
- Pressure pre-set valve on request (standard equipment for the solenoid valves).
- Glycerine-damped pressure gauge, Ø 100 mm, class 1.0 %.
- Control by manual directional valve (with motor start-stop remote control) or solenoid valve with pendant remote control box.



RPES 10 ... (10 t press)  
RPES 30 ... (30 t press)

## Technical data RPY and RPES

Model	Art.-No.	Frame design	Capacity t	Cylinder model	Cylinder stroke mm	Piston return	Type of pump	Valve control	Pump model
RPY-1015 M-2	N13700896	bench press	10	YS-10/150	150	spring	manual	manual	HPS-2/0,7 A
RPY-1025 EM-PYE 07	N13700021	bench press	10	YS-10/250	250	spring	electric	manual	PYE-07/3/10/3M-RPY
RPY-2316 M-2	N13700898	bench press	23	YS-23/160	160	spring	manual	manual	HPS-2/0,7 A
RPY-2325 M-2	N13700900	bench press	23	YS-23/250	250	spring	manual	manual	HPS-2/2 A
RPY-2325 EM-PYE 07	N13700017	bench press	23	YS-23/250	250	spring	electric	manual	PYE-07/3/10/3M-RPY
RPES-1015 M-2	N13700004	floor press	10	YS-10/150	150	spring	manual	manual	HPS-2/0,7 A
RPES-1025 EM-PYE 07	N13700022	floor press	10	YS-10/250	250	spring	electric	manual	PYE-07/3/10/3M-RPY
RPES-2316 M-2	N13700006	floor press	23	YS-23/160	160	spring	manual	manual	HPS-2/0,7 A
RPES-2325 M-2	N13700900	floor press	23	YS-23/250	250	spring	manual	manual	HPS-2/2 A
RPES-2325 EM-PYE 07	N13700020	floor press	23	YS-23/250	250	spring	electric	manual	PYE-07/3/10/3M-RPY
RPY-5015 EM	N13701005	floor press	50	YH-50/150	150	hydraulic	electric	manual	PY-04/2/5/4M
RPY-5035 EM	N13700912	floor press	50	YH-50/350	350	hydraulic	electric	manual	PY-04/2/5/4M
RPY-5035 EE	N13700913	floor press	50	YH-50/350	350	hydraulic	electric	solenoid	PYS-07/3/10/4 E
RPY-5050 EE	N13701006	floor press	50	YH-50/500	500	hydraulic	electric	solenoid	PYS-07/3/10/4 E
RPY-10035 EM	N13700914	floor press	100	YH-100/350	350	hydraulic	electric	manual	PY-07/3/10/4 M-RPY
RPY-10035 EE	N13700915	floor press	100	YH-100/350	350	hydraulic	electric	solenoid	PY-07/3/10/4 E
RPY-10050 EM	N13700916	floor press	100	YH-100/500	500	hydraulic	electric	manual	PY-07/3/10/4 M-RPY
RPY-10050 EE	N13701008	floor press	100	YH-100/500	500	hydraulic	electric	solenoid	PY-07/3/10/4 E
RPY-20035 EM	N13700917	floor press	200	YH-200/350	350	hydraulic	electric	manual	PY-11/3/20/4 M-RPY
RPY-20035 EE	N13700918	floor press	200	YH-200/350	350	hydraulic	electric	solenoid	PY-11/3/20/4 E
RPY-20050 EM	N13700919	floor press	200	YH-200/500	500	hydraulic	electric	manual	PY-11/3/20/4 M-RPY
RPY-20050 EE	N13701017	floor press	200	YH-200/500	500	hydraulic	electric	solenoid	PY-11/3/20/4 E

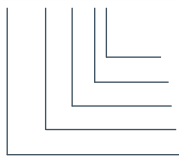

### Code explanation

Valve control : M = manual valve, E = solenoid valve with pendant remote control  
 Pump : M = hand pump, E = electric pump  
 Piston stroke : 15 = 150 mm, 16 = 160 mm, 25 = 250 mm, 35 = 350 mm, 50 = 500 mm  
 Capacity max. : 10 = 10 t, 23 = 23 t, 50 = 50 t, 100 = 100 t, 200 = 200 t  
 Model

## Dimensions RPY and RPES (frame only)

Model	RPY-10	RPY-23	RPES-10	RPES-23	RPY-50	RPY-100	RPY-200
A min., mm	-	-	50	50	280	270	320
A max., mm	440	440	930	930	1120	830	1000
B, mm	380	380	700	700	820	1000	1000
C, mm	510	510	650	650	1020	1300	1400
D, mm	-	-	500	500	1200	1480	1580
E, mm	180	180	-	-	920	860	1040
F, mm	-	-	150	150	140	140	170
G, mm	-	-	240	240	255	335	450
H, mm	840	840	1695	1695	2000	2000	2430
I, mm	300	300	245	245	315	395	550
K, mm	-	-	-	-	1000	1000	1000
L, mm	-	-	-	-	383	333	400
Weight approx., kg	77	77	94	94	450	950	2380

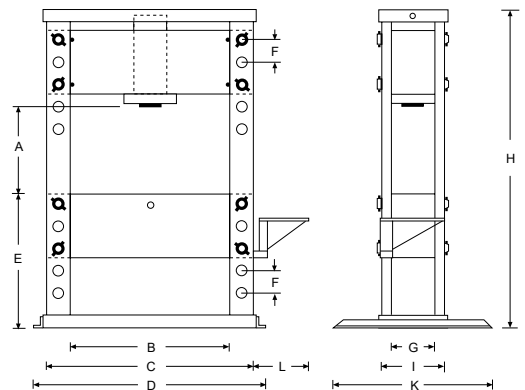

RPY-50, 100 and 200

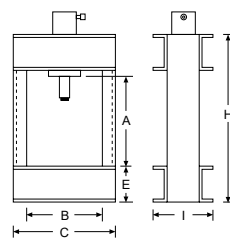

RPY-10 up to 23

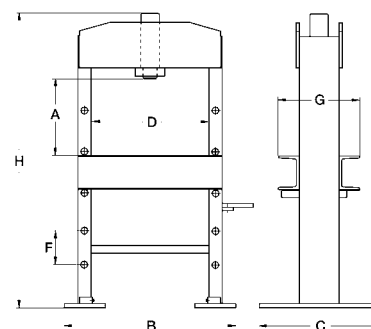

RPES-10 up to 30

## Selection chart for single-acting systems

### Which hand pump is suitable for which hydraulic cylinder?

The appropriate hand pump model basically depends on the oil volume of the selected hydraulic cylinders.

To assist you in your choice please find proposals for the most common cylinders in our range.

### How to find the right hand pump in the following charts?

The chosen hydraulic cylinder can be found in the first column.

### Several hydraulic cylinders connected to one hand pump:

In those cases where several hydraulic cylinders are connected to one hand pump, the oil volume must be multiplied by the number of connected cylinders. The reservoir of the hand pump must be at least equal to the required total oil volume (plus reserve). If the reserve is very small it may be necessary to top up the reservoir after the air-bleeding procedure, depending on the length of the hydraulic hose. During further operation there is no need to consider the volume of the connected hydraulic hose (regardless of the length) because hoses always remain filled.

### Double-acting systems:

Please note that while advancing a double-acting cylinder, about 1/3 of the cylinder's oil volume flows back to the reservoir (coming from the piston chamber). After the air-bleeding procedure both oil chambers will remain filled.



## INFO

Please contact us for any questions regarding the configuration of complex systems according to your specific requirement.

## Selection chart for single-acting systems

Model	Oil volume cm <sup>3</sup>	Hand pumps single-stage HPS-1/0,7A 700 cm <sup>3</sup>	Hand pumps two-stage HPS-2/0,3A 300 cm <sup>3</sup>	Hand pumps two-stage HPS-2/0,7A 700 cm <sup>3</sup>	Hand pumps two-stage HPS-2/1,3A 1300 cm <sup>3</sup>	Hand pumps two-stage HPS-2/2A 2000 cm <sup>3</sup>	Hand pumps two-stage HPS-2/4A 4000 cm <sup>3</sup>	Hand pumps two-stage HPS-2/6,5A 6500 cm <sup>3</sup>
YS-5/15	11	+++	+++	-	-	-	-	-
YS-5/25	18	+++	+++	+++	-	-	-	-
YS-5/75	53	+++	+++	+++	-	-	-	-
YS-5/127	90	+++	+++	+++	-	-	-	-
YS-5/180	127	+++	+++	+++	-	-	-	-
YS-10/25	37	+++	++	+++	-	-	-	-
YS-10/50	73	+++	++	+++	-	-	-	-
YS-10/100	146	+++	++	+++	-	-	-	-
YS-10/150	218	+++	-	+++	-	-	-	-
YS-10/200	291	+++	-	+++	-	-	-	-
YS-10/250	363	+++	-	+++	++	-	-	-
YS-10/300	463	++	-	+++	++	-	-	-
YS-15/25	53	+++	++	+++	-	-	-	-
YS-15/50	106	+++	++	+++	-	-	-	-
YS-15/100	213	+++	-	+++	++	-	-	-
YS-15/150	319	+++	-	+++	++	-	-	-
YS-15/200	425	++	-	+++	++	++	-	-
YS-15/250	531	++	-	+++	+++	++	-	-
YS-15/300	637	-	-	-	+++	+++	-	-
YS-15/350	744	-	-	-	+++	+++	-	-
YS-23/25	83	+++	-	+++	-	-	-	-
YS-23/50	166	+++	-	+++	-	-	-	-
YS-23/100	332	+++	-	+++	++	++	-	-
YS-23/160	531	++	-	+++	+++	++	-	-
YS-23/210	697	-	-	-	+++	++	-	-
YS-23/250	830	-	-	-	+++	++	-	-
YS-23/300	996	-	-	-	+++	++	-	-
YS-23/345	1145	-	-	-	+++	+++	-	-
YS-30/125	552	++	-	+++	+++	+++	-	-
YS-30/200	884	-	-	-	+++	+++	-	-
YS-50/50	355	++	-	+++	+++	+++	-	-
YS-50/100	709	-	-	-	+++	+++	-	-
YS-50/160	1135	-	-	-	+++	+++	-	-
YS-50/320	2269	-	-	-	-	-	+++	++
YS-70/150	1478	-	-	-	-	+++	+++	++
YS-70/330	3252	-	-	-	-	-	++	+++
YS-100/100	1432	-	-	-	-	+++	++	++
YS-100/200	2863	-	-	-	-	-	+++	++
YLS-10/35	51	+++	+++	+++	-	-	-	-
YLS-20/45	128	+++	++	+++	-	-	-	-
YLS-30/60	266	++	++	+++	-	-	-	-
YLS-50/60	426	++	-	+++	++	++	-	-
YLS-100/55	788	-	-	-	+++	+++	-	-
YFS-10/11	16	+++	+++	+++	-	-	-	-
YFS-20/15	31	+++	+++	+++	-	-	-	-
YFS-30/15	66	+++	+++	+++	-	-	-	-
YFS-50/15	107	+++	++	+++	-	-	-	-
YFS-100/15	215	+++	-	+++	-	-	-	-
YCS-12/40	71	+++	+++	+++	-	-	-	-
YCS-12/75	132	+++	+++	+++	-	-	-	-
YCS-21/50	153	+++	++	+++	-	++	-	-
YCS-21/150	458	+++	-	+++	++	++	-	-
YCS-33/60	287	+++	-	+++	-	-	-	-
YCS-33/150	716	-	-	-	+++	+++	-	-
YCS-57/70	562	++	-	+++	+++	+++	-	-
YCS-62/150	1330	-	-	-	-	+++	+++	-
YCS-93/75	990	-	-	-	+++	+++	-	-

+++ recommended hand pump

++ these combinations can also be used, but the oil volume of the hand pump is quite small

- these combinations should not be chosen, because the oil volumes of the hand pumps are too small to fill the selected cylinder (too large and bulky, respectively)

**Selection chart for double-acting systems**

Model	Oil volume cm <sup>3</sup>	Hand pumps two-stage HPH-2/0,7A 700 cm <sup>3</sup>	Hand pumps two-stage HPH-2/2A 2000 cm <sup>3</sup>	Hand pumps two-stage HPH-2/4A 4000 cm <sup>3</sup>	Hand pumps two-stage HPH-2/6,5A 6500 cm <sup>3</sup>	Hand pumps two-stage HPH-2/10A 10000 cm <sup>3</sup>
YCH-33/150	716	++	+++	-	-	-
YCH-33/250	1200	-	+++	++	-	-
YCH-62/250	2220	-	+++	+++	-	-
YCH-93/250	3320	-	-	+++	++	-
YCH-100/40	578	+++	+++	-	-	-
YCH-140/200	4080	-	-	+++	++	-
YH-5/30	21	+++	-	-	-	-
YH-5/80	57	+++	-	-	-	-
YH-5/150	106	+++	-	-	-	-
YH-10/30	44	+++	-	-	-	-
YH-10/80	116	+++	-	-	-	-
YH-10/150	218	+++	-	-	-	-
YH-10/250	363	+++	++	-	-	-
YH-20/50	142	+++	++	-	-	-
YH-20/150	424	+++	+++	-	-	-
YH-20/250	707	++	+++	-	-	-
YH-30/200	884	-	+++	-	-	-
YH-30/350	1547	-	+++	-	-	-
YH-50/150	1064	-	+++	-	-	-
YH-50/350	2481	-	++	+++	-	-
YH-50/500	3544	-	-	+++	++	-
YH-70/150	1478	-	+++	-	-	-
YH-70/350	3449	-	-	+++	++	-
YH-100/50	716	+++	+++	-	-	-
YH-100/150	2148	-	+++	+++	-	-
YH-100/350	5010	-	-	++	+++	-
YH-100/500	7157	-	-	-	++	+++
YH-200/150	4253	-	-	+++	+++	-
YH-200/350	9924	-	-	-	++	+++
YH-200/500	14177	-	-	-	-	+++

+++ recommended hand pump

++ these combinations can also be used, but the oil volume of the hand pump is quite small

- these combinations should not be chosen, because the oil volumes of the hand pumps are too small to fill the selected cylinder (too large and bulky, respectively)

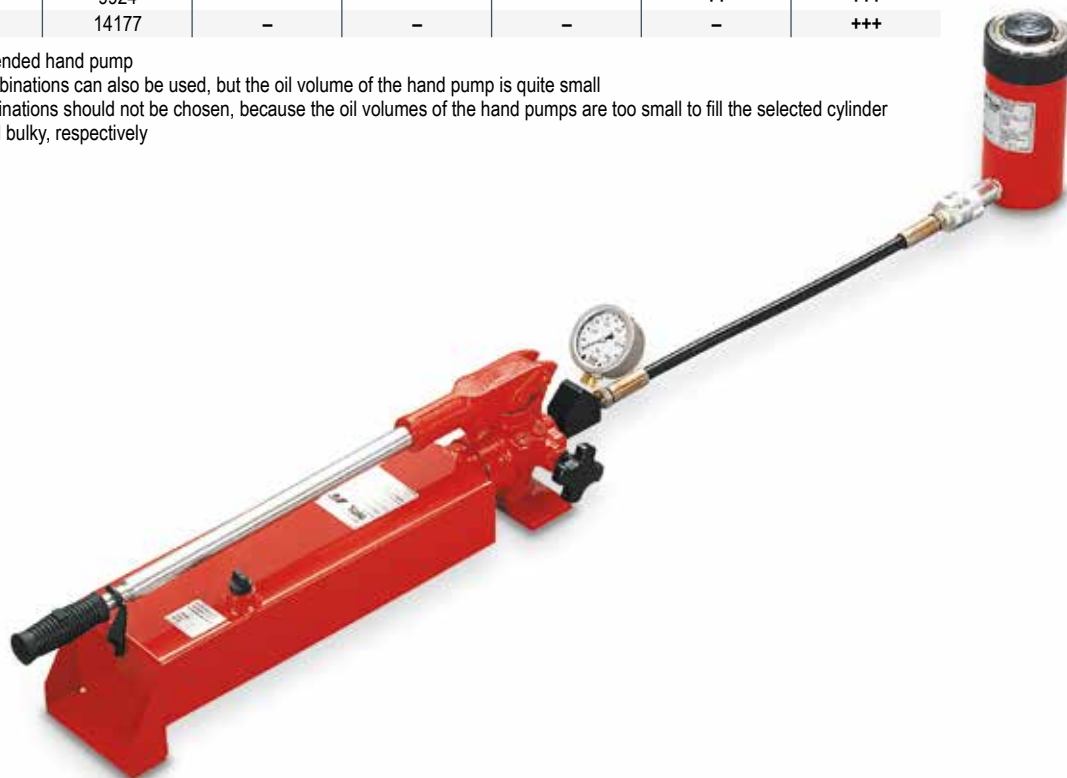



## Pump and cylinder speed chart

### Hand pumps

For hand pumps the figures given correspond to the number of pump strokes to achieve a piston travel of 10 mm.

### Power pumps

For power pumps the piston travel speed is indicated in mm/s.

### Double-acting hydraulic cylinders

Please note that double-acting cylinders (YCH, YH and YEHB) always retract faster than they advance, due to the different oil chamber volumes.

### Reservoir volumes

The reservoir volumes of hand pumps shall at least correspond to the oil volume which is necessary to advance all connected hydraulic cylinders (plus reserve).

Motor pump reservoirs should have at least twice the total required oil quantity (better 3 or 4 times) depending on the operation conditions. For continuous operation choose extra large reservoirs to avoid excessive heating-up of the hydraulic oil.

## Hand pumps

Cylinder size  t	Number of pump strokes for 10 mm strokes	
	HPS-2/0,7 A up to HPS-2/10 A ND	HPS-1/0,7 A up to HPS-2/10 A HD
5	1	4
10	1	7
15	2	11
20	2	14
21	2	15
23	3	17
30	3	22
33	4	24
50	5	35
57	6	40
62	7	44
70	8	49
85	9	61
93	10	66
100	11	72
140	15	100
200	22	142
220	24	157
340	32	205
430	47	308
560	62	402
670	74	481
880	97	628

ND = Low-pressure stage (unloaded stroke)  
HD = High-pressure stage (loaded stroke)



## Power pumps

Cylinder size t	Piston travel speed in mm/s												
	PY-04 ND	PY-04 HD	PY-07 ND	PY-07 HD	PY-11 ND	PY-11 HD	PY-22 ND	PY-22 HD	PYE-40 HD	PYE-55 HD	PYE-75 HD	PYE-110 HD	PYE-180 HD
5	99.9	5.4	155.9	14.2	–	–	–	–	63.8	–	–	–	–
10	48.7	2.6	75.9	6.9	103.5	11.5	–	–	31.1	46	69	–	–
15	33.3	1.8	51.9	4.7	70.8	7.9	–	–	21.2	31.5	47.2	62.9	–
20	25.0	1.4	39.0	3.5	53.2	5.9	106.9	12.4	15.9	23.6	35.4	47.3	75.0
21	23.2	1.3	36.1	3.3	49.3	5.5	99.1	11.5	14.8	21.9	32.8	43.8	69.5
23	21.3	1.2	33.2	3.0	45.3	5.0	91.1	10.6	13.6	20.1	30.2	40.3	63.9
30	16.0	0.9	24.9	2.3	34.0	3.8	68.4	7.9	10.2	15.1	22.7	30.2	48.0
33	14.8	0.8	23.1	2.1	31.5	3.5	63.4	7.4	9.5	14	21	28.0	44.5
50	10.0	0.5	15.6	1.4	21.2	2.4	42.6	4.9	6.4	9.4	14.1	18.8	29.9
57	8.8	0.5	13.7	1.2	18.7	2.1	37.7	4.4	5.6	8.3	12.5	16.7	26.4
62	8.0	0.4	12.4	1.1	17.0	1.9	34.1	4.0	5.1	7.5	11.3	15.1	24.0
70	7.2	0.4	11.2	1.0	15.3	1.7	30.7	3.6	4.6	6.8	10.2	13.6	21.5
85	5.8	0.3	9.0	0.8	12.3	1.4	24.7	2.9	3.7	5.4	8.2	10.9	17.3
93	5.4	0.3	8.4	0.8	11.4	1.3	22.9	2.7	3.4	5.1	7.6	10.1	16.1
100	4.9	0.3	7.7	0.7	10.5	1.2	21.1	2.5	3.2	4.7	7.0	9.3	14.8
140	3.5	0.2	5.0	0.5	7.1	0.8	14.9	1.7	2.2	3.3	5.0	6.6	10.0
200	2.5	0.1	3.2	0.4	5.3	0.6	10.7	1.2	1.6	2.4	3.5	4.7	7.5
220	2.2	0.1	3.5	0.3	4.5	0.5	9.6	1.1	1.4	2.1	3.2	4.2	6.4
310	–	–	2.3	0.2	3.7	0.4	6.9	0.8	1.0	1.5	2.3	3.0	4.6
410	–	–	1.8	0.2	2.4	0.3	5.2	0.6	0.8	1.2	1.8	2.3	3.5
520	–	–	1.4	0.1	1.9	0.2	4.1	0.5	0.6	0.9	1.4	1.8	2.7
610	–	–	1.1	0.1	1.7	0.2	3.5	0.4	0.5	0.8	1.2	1.6	2.3
830	–	–	0.9	0.1	1.2	0.1	2.6	0.3	0.4	0.6	0.9	1.1	1.7

ND = Low-pressure stage (unloaded stroke)  
 HD = High-pressure stage (loaded stroke)  
 – = combination not recommended or not possible

