

GENERAL INFORMATION

This user information presents a general review regarding the application of cranes and does not substitute the existing operating instructions for specific products!

Lifting and slewing operations may be carried out by competent users (trained in theory and practice) only. When operated correctly, our cranes will offer the highest degree of safety in line with long life expectancy and avoid damage to products and people.

Yalesystems cranes are manufactured in accordance with the machinery directive 2006/42/EC and the latest DIN 15018 H2 B2 (gantry cranes H2 B3) and correspond to the VDE regulations.

All components are mechanically shot blast, then primed and coated with RAL 1023 (yellow) paint, D.F.T. approx. 60 micron.

Modification of delivery condition

Design and finish of the cranes may not be modified by e.g. installation of outside supplied parts, bending, welding, grinding, removal of parts, added bores, removal of safety devices like locking mechanisms, locking pins, safety latches etc.

Limitations of operation

Temperature

Cranes may normally be operated at ambient temperatures between -10°C up to +50°C. These values are approximate and may deviate from the specific givings of the product concerned. The accurate data are given in the current operating instructions.

Chemicals

Cranes may not be operated without hesitation in the area of chemicals or chemical vapours – consult our specialists for advice. Cranes which have been subject to chemicals or vapours must be taken out of service and inspected by us.

INFO

You will find the General Terms and Conditions at the end of the catalogue.

Please note the information on our training courses on page 4.

Transport of people

Transport of people with cranes is generally forbidden!

Operation in danger zones

Lifting or transport of loads must be avoided while personnel are in the danger zone. People are not allowed to pass over or under a suspended load.

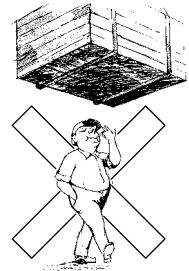

Electrical hazards

Please consult the specific operating instructions for possible electrical hazards. Electrical connections may only be performed by authorized persons resp. companies!

Maintenance and repair

To ensure safe operation, all cranes must be subjected to regular inspections according to the maintenance instructions given by the manufacturer. For legal obligations refer to DGUV Vorschrift 52 (BGVD6).

Depending on the frequency and impact of applications, the crane has to be maintained, at least once per year or in case of obvious damages, by competent persons resp. inspectors.

Repairs and inspections may only be carried out by competent persons resp. inspectors who use original spare parts. Repairs and inspections must be recorded consecutively.

Inspections

The contractor has to make sure that powered cranes are inspected prior to initial operation and after significant modifications by a competent person. This is also applicable for hand operated cranes with a capacity of more than 1000 kg.

For cranes according to § 3a para. 3 DGUV Vorschrift 52 (BGVD6) the inspection before initial operation consists of advance survey, inspection of building and quality acceptance.

The inspection prior to initial operation is not required for cranes, which are delivered ready-to-use and with certificate of a type approval or EC declaration of conformity.

Technical questionnaire to identify the suitable crane system

Company: _____

Date: _____

Contact: _____

e-Mail: _____

Phone: _____

Fax: _____

- Wall-mounted jib crane**
- Floor-mounted jib crane**
- For outdoor use**

Capacity _____ kg
 Slewing range _____
 Boom length A _____ mm
 Boom clearance UK _____ mm
 or: ceiling clearance H _____ mm
 or: overall height B _____ mm
 or: highest hook position _____ mm

Accessories

- Increased paint thickness
- Hot-dip galvanizing
- Boom locks
- Slewing range stoppers
- Electrically driven slewing gear
- Slewing brake

Power supply

- Round cable
- Festooned cable
- Suspended control

Mounting for wall-mounted jib crane

- Threaded rods/anchor bolts
- Pillar embracing

Mounting for floor-mounted jib crane

- Anchors and template
- Standard base plate (welded) incl. anchors/rawlplug
- Dowel base plate (bolted) incl. anchors/rawlplug

Hoist

- Manual hoist
- Electric chain hoist (single speed)
- Electric chain hoist (2 speeds)

- Gantry crane**

Capacity _____ kg
 Gantry width – inside – a _____ mm
 Gantry width – outside – A _____ mm
 Beam clearance UK _____ mm
 or: ceiling clearance H _____ mm
 or: overall height B _____ mm
 or: highest hook position _____ mm

Accessories

- Increased paint thickness
- Hot-dip galvanizing

Power supply

- Round cable
- Festooned cable
- Suspended control

Trolley

- With push trolley
- With geared trolley
- With electric trolley (single speed)
- With electric trolley (2 speeds)

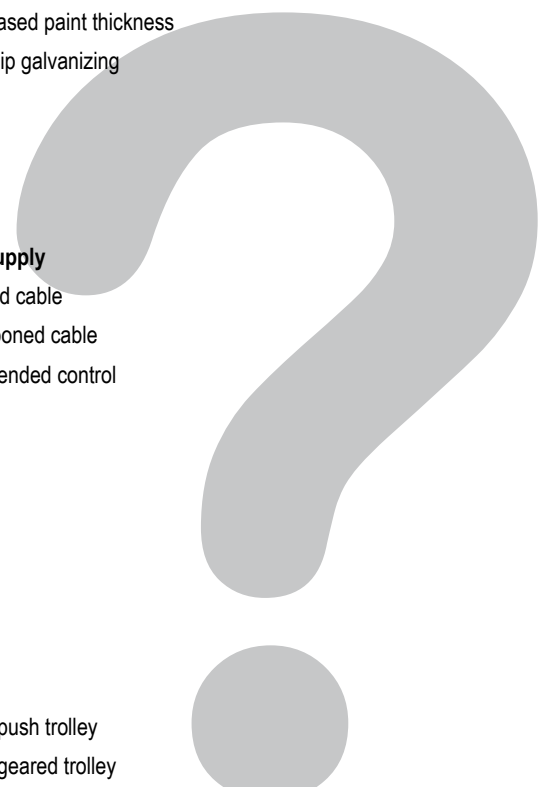

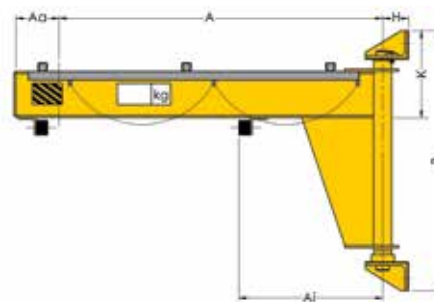
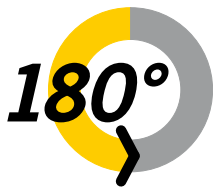

INFO

Mounting supports and walls are within the responsibility of the user.

Scope of delivery

- The electrical system is equipped with a lockable main switch, round cable power supply with cable support pipes for booms up to 4000 mm.
- From 4500 mm upwards, the boom is equipped with a festooned cable power supply. Due to cable sag on low cranes, we recommend the use of festooned cables even on short booms.
- Trolley stoppers at the front and at the back.
- Cranes are supplied with an operating manual and complete manufacturer's documentation.

PMS Wall-mounted jib crane

Elevated boom with optimal height, slewing range 180°

Lightweight, twist-free steel girder construction with low headroom. The boom is fitted with a bearing and a wall bracket for anchoring the crane to a concrete wall.

Mounting a jib crane to a wall, in combination with a festooned cable system, may lead to restrictions in the slewing range of the boom. This being the case, slew stoppers (buffers) should be fitted accordingly.

Mounting

- Wall mounting, using threaded rods that go through the wall and that are bolted to the wall with counter plates and nuts.
- Pillar embracing with anchor bolts and wall bracket. Bracket plate max. 500 mm, anchor bolts (threaded rods) max. 1000 mm.
- Alternative mounting systems on request.

Optional

- Slew stoppers (buffers) can be fitted on building site for a pre-determined fixed slewing range.
- Slewing brake, to control the boom speed during slewing. Recommended for a boom length of more than 5 m or a headroom of more than 4 m. This prevents uncontrolled movement of the boom.
- Increased paint layer (120 µm) or hot-dip galvanisation for outdoor use.
- Manual locking device, to hold the boom in a fixed position (wind protection).
- Hoist cover for outdoor use.

Standard delivery programme PMS

Model	Capacity kg	Boom length in mm										
		2000	2500	3000	3500	4000	4500	5000	5500	6000	6500	7000
PMS 125	125	•	•	•	•	•	•	•	•	•	•	•
PMS 200	200	•	•	•	•	•	•	•	•	•	•	•
PMS 250	250	•	•	•	•	•	•	•	•	•	•	•
PMS 400	400	•	•	•	•	•	•	•	•	•	•	•
PMS 500	500	•	•	•	•	•	•	•	•	•	•	•
PMS 800	800	•	•	•	•	•	•	•	•	•	•	•
PMS 1000	1000	•	•	•	•	•	•	•	•	•	•	•
PMS 1600	1600	•	•	•	•	•	•	•	•	•	•	•
PMS 2000	2000	•	•	•	•	•	•	•	•	•	•	•
PMS 2500	2500	•	•	•	•	•	•	•	•	•	•	•

Mounting systems wall-mounted jib cranes

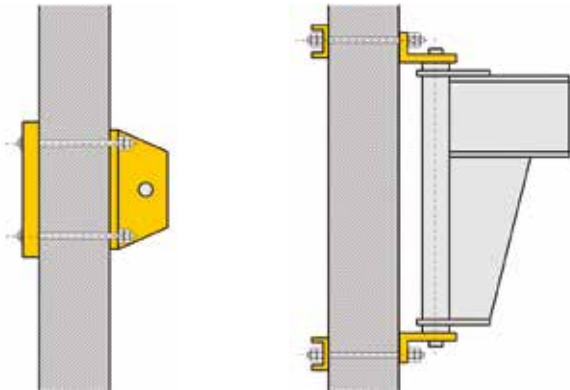

Wall mounting, using threaded rods going through the wall and being fixed to the wall with counter plates and nuts

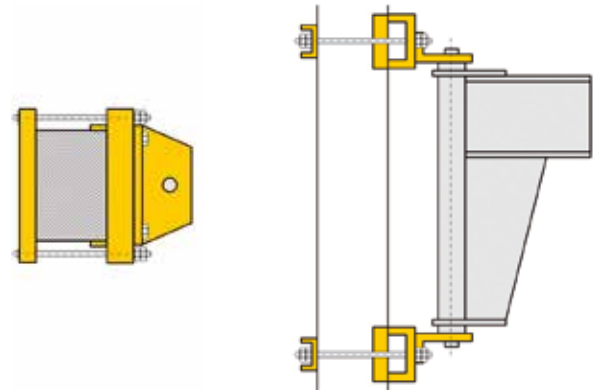

Pillar embracing with anchor bolts and wall bracket (bracket plate max. 500 mm, anchor bolts max. 1000 mm)

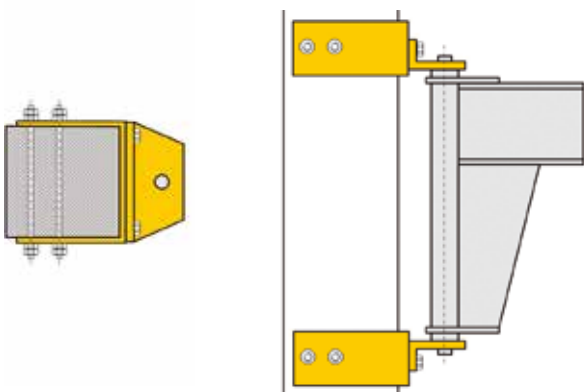
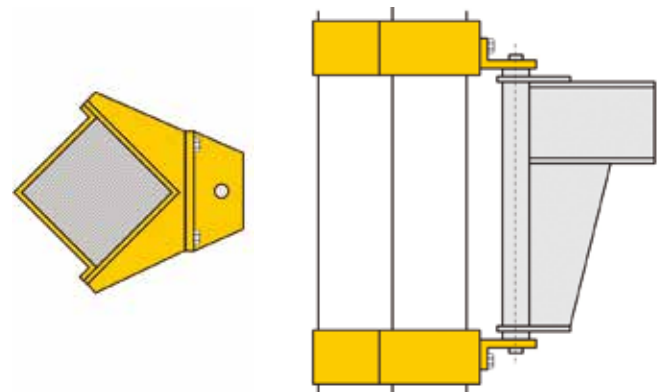
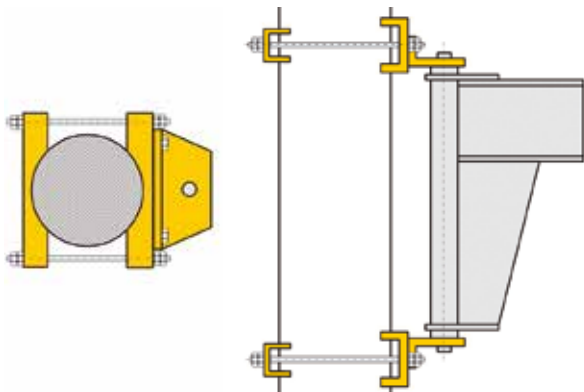

INFO

If wall-mounted jib cranes are mounted directly on the wall and festooned cable power supply is used, the slewing range may be limited depending on the size of the hoist.

Further fastening possibilities such as weld-on brackets, ceiling mounting etc. on request.

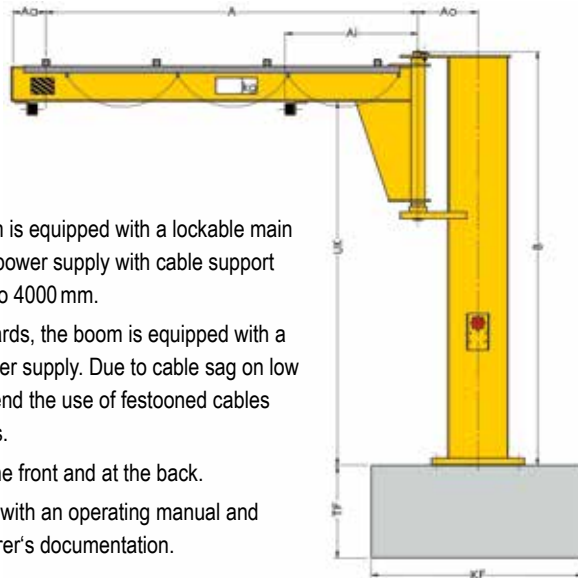
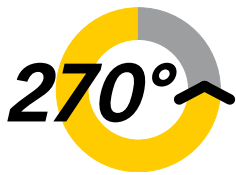

Scope of delivery

- The electrical system is equipped with a lockable main switch, round-cable power supply with cable support pipes for booms up to 4000 mm.
- From 4500 mm upwards, the boom is equipped with a festooned cable power supply. Due to cable sag on low cranes, we recommend the use of festooned cables even on short booms.
- Trolley stoppers at the front and at the back.
- Cranes are supplied with an operating manual and complete manufacturer's documentation.

**PFSP
Floor-mounted jib crane**

Elevated boom with optimal height, slewing range 270°

Lightweight, twist-free steel girder construction with low headroom. The boom is fitted with a bearing, pillar made from reinforced steel pipe.

Depending on the size of the hoist and in combination with festooned power cables, restrictions in the slewing range of the boom may be possible.

Mounting

- Base flange with anchor bolts and template.
- Anchoring the base plate (welded) including mortar cartridges, anchor studs (complete with nuts, locknuts and washers).
- Anchoring the dowel base plate (bolted) including mortar cartridges, anchor studs (complete with nuts, locknuts and washers).
- Mobile unit for changeable location.

Optional

- Slew stoppers (buffers) can be fitted on building site for a pre-determined fixed slewing range.
- Slewing brake, to control the boom speed during slewing. Recommended for a boom length of more than 5 m or a headroom of more than 4 m. This prevents uncontrolled movement of the boom.
- Increased paint layer (120 µm) or hot-dip galvanisation for outdoor use.
- Manual locking device, to hold the boom in a fixed position (wind protection).
- Hoist cover for outdoor use.

INFO

Mounting systems, please see page 157.

Standard delivery programme PFSP

Model	Capacity kg	Boom length in mm										
		2000	2500	3000	3500	4000	4500	5000	5500	6000	6500	7000
PFSP 125	125	•	•	•	•	•	•	•	•	•	•	•
PFSP 200	200	•	•	•	•	•	•	•	•	•	•	•
PFSP 250	250	•	•	•	•	•	•	•	•	•	•	•
PFSP 400	400	•	•	•	•	•	•	•	•	•	•	•
PFSP 500	500	•	•	•	•	•	•	•	•	•	•	•
PFSP 800	800	•	•	•	•	•	•	•	•	•	•	•
PFSP 1000	1000	•	•	•	•	•	•	•	•	•	•	•
PFSP 1600	1600	•	•	•	•	•	•	•	•	•	•	•
PFSP 2000	2000	•	•	•	•	•	•	•	•	•	•	•
PFSP 2500	2500	•	•	•	•	•	•	•	•	•	•	•

PFM Floor-mounted jib crane

Elevated boom with optimal height, slewing range 360°

Lightweight, twist-free steel girder construction with low headroom. Compact rotating head for ideal construction dimensions; access from above ensures easy assembly. The boom is fitted with a roller bearing, pillar made from reinforced steel pipe.

Depending on the size of the hoist and in combination with festooned power cables, restrictions in the slewing range of the boom may be possible.

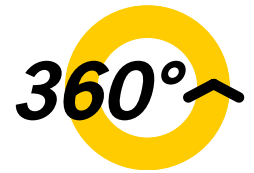

Mounting

- Base flange with anchor bolts and template.
- Anchoring the base plate (welded) including mortar cartridges, anchor studs (complete with nuts, locknuts and washers).
- Anchoring the dowel base plate (bolted) including mortar cartridges, anchor studs (complete with nuts, locknuts and washers).
- Mobile unit for changeable location.

Optional

- Slew stoppers (buffers) can be fitted on building site for a pre-determined fixed slewing range.
- Slewing brake, to control the boom speed during slewing. Recommended for a boom length of more than 5 m or a headroom of more than 4 m. This prevents uncontrolled movement of the boom.
- Increased paint layer (120 µm) or hot-dip galvanisation for outdoor use.
- Manual locking device, to hold the boom in a fixed position (wind protection).
- Hoist cover for outdoor use.

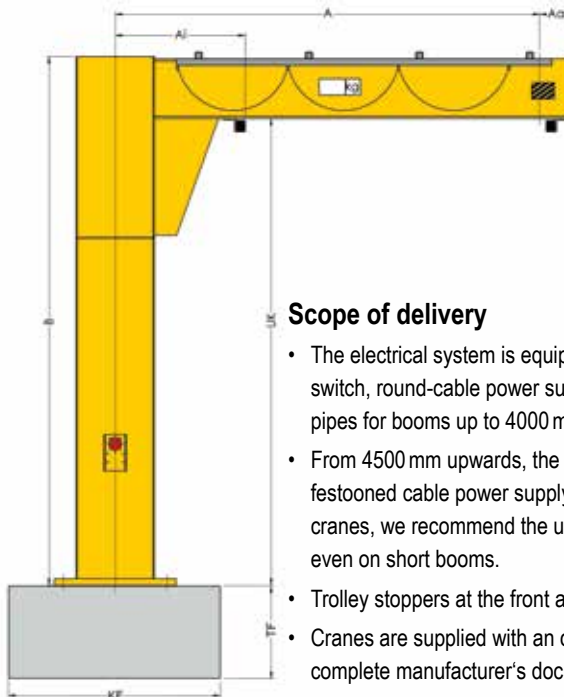

Scope of delivery

- The electrical system is equipped with a lockable main switch, round-cable power supply with cable support pipes for booms up to 4000 mm.
- From 4500 mm upwards, the boom is equipped with a festooned cable power supply. Due to cable sag on low cranes, we recommend the use of festooned cables even on short booms.
- Trolley stoppers at the front and at the back.
- Cranes are supplied with an operating manual and complete manufacturer's documentation.

INFO

Mounting systems, please see page 157.

Standard delivery programme PFM

Model	Capacity kg	Boom length in mm										
		2000	2500	3000	3500	4000	4500	5000	5500	6000	6500	7000
PFM 125	125	•	•	•	•	•	•	•	•	•	•	•
PFM 200	200	•	•	•	•	•	•	•	•	•	•	•
PFM 250	250	•	•	•	•	•	•	•	•	•	•	•
PFM 400	400	•	•	•	•	•	•	•	•	•	•	•
PFM 500	500	•	•	•	•	•	•	•	•	•	•	•
PFM 800	800	•	•	•	•	•	•	•	•	•	•	•
PFM 1000	1000	•	•	•	•	•	•	•	•	•	•	•

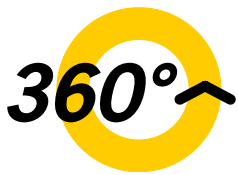

**PFP
Floor-mounted jib crane**

Elevated boom with optimal height, slewing range 360°

Heavy, robust twist-free steel girder construction. Structural steel crane-boom. Compact rotating head for ideal construction dimensions; access from above ensures easy assembly. The boom is fitted with a roller bearing, pillar made from reinforced steel pipe.

Depending on the size of the hoist and in combination with festooned power cables, restrictions in the slewing range of the boom may be possible.

Mounting

- Base flange with anchor bolts and template.
- Anchoring the dowel base plate (bolted) including mortar cartridges, anchor studs (complete with nuts, locknuts and washers).

Optional

- Electrically driven slewing gear.
- Slew stoppers (buffers) can be fitted on building site for a pre-determined fixed slewing range.
- Limit switches to limit the boom slewing range (before hitting a fixed object the motor switches off automatically).
- Increased paint layer (120 µm) or hot-dip galvanisation for outdoor use.
- Manual locking device, to hold the boom in a fixed position (wind protection).
- Hoist cover for outdoor use.

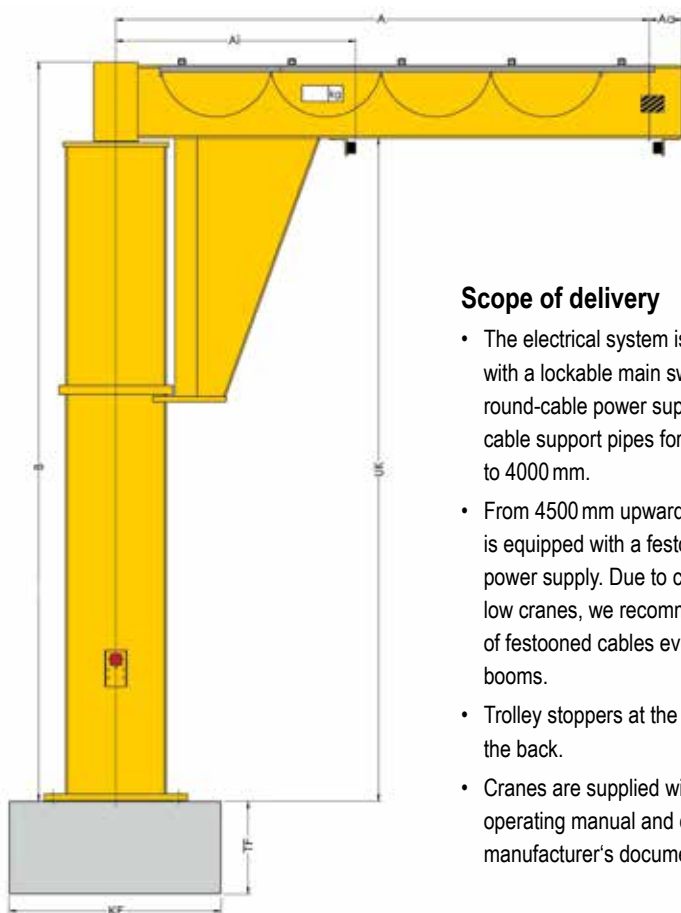

Scope of delivery

- The electrical system is equipped with a lockable main switch, round-cable power supply with cable support pipes for booms up to 4000 mm.
- From 4500 mm upwards, the boom is equipped with a festooned cable power supply. Due to cable sag on low cranes, we recommend the use of festooned cables even on short booms.
- Trolley stoppers at the front and at the back.
- Cranes are supplied with an operating manual and complete manufacturer's documentation.

Standard delivery programme PFP

Model	Capacity kg	Boom length in mm										
		2000	2500	3000	3500	4000	4500	5000	5500	6000	6500	7000
PFP 500	500	•	•	•	•	•	•	•	•	•	•	•
PFP 800	800	•	•	•	•	•	•	•	•	•	•	•
PFP 1000	1000	•	•	•	•	•	•	•	•	•	•	•
PFP 1600	1600	•	•	•	•	•	•	•	•	•	•	•
PFP 2000	2000	•	•	•	•	•	•	•	•	•	•	•
PFP 2500	2500	•	•	•	•	•	•	•	•	•	•	•
PFP 3200	3200	•	•	•	•	•	•	•	•	•	•	•

Safety distances in accordance with the accident prevention regulations for cranes DGUV Vorschrift 52 (BGV D6) § 11 and § 32

The following safety distances are only valid for floor-controlled cranes, without platforms, walkways or similar, on the jib with a load capacity of less than 10 t.

Movement manual	Safety distance		
	So = top	Ss = side	Su = bottom
Lifting	100*	100*	100*

Movement power-driven, floor-controlled	Safety distance		
	So = top	Ss = side	Su = bottom
Lifting	100*	100*	100*
Lifting and travelling	100*	100*	500
Lifting, travelling and slewing	100*	100* (500)	500

Safety distances for cranes with a load capacity up to 10000 kg
*No regulation (100 mm recommended)

Ss... for power-driven slewing motion, the safety distance must be complied with, if the possible crushing point is within the traffic and working area.

In general, the traffic and working area ranges from the upper edge of the ground up to 2.5m room height.

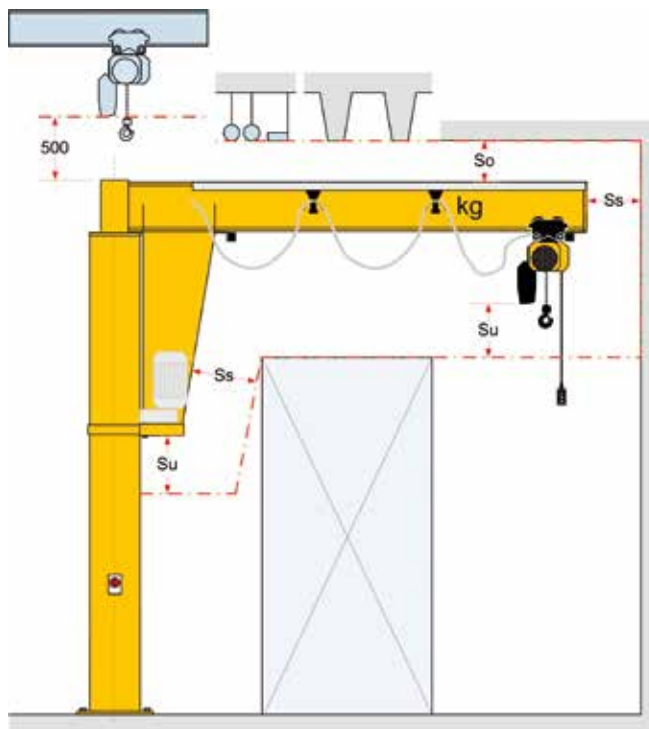

Mounting systems for floor-mounted jib cranes

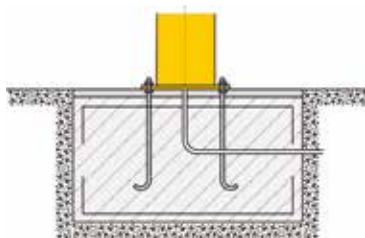

Anchor bolts with template for preparation of the foundation through the customer.

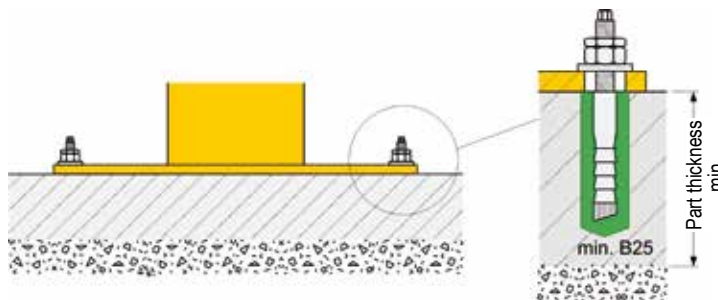

Standard base plate (welded) for anchor-bolt connection on existing concrete floor instead of welded-on base flange (only for operation inside a building) incl. HVZ dynamic anchor bolts.

INFO

Further capacities and boom lengths on request.

Further fastening possibilities such as weld-on brackets, ceiling mounting etc. on request.

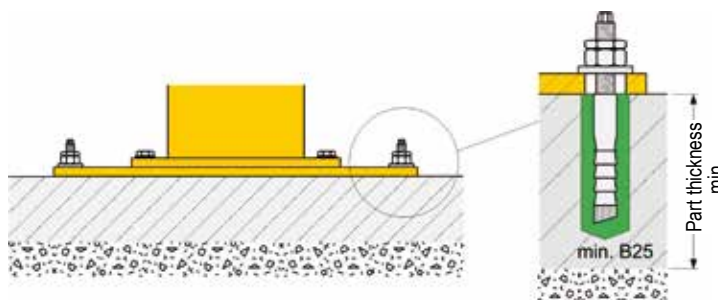

Dowel base plate for anchor-bolt connection on existing concrete floor (only for operation inside a building) incl. HVZ dynamic anchor bolts.

INFO

Operating conditions for standard and intermediate base plates

- The thickness of the concrete floor slab for M 12 x 95 HVC dynamic anchor bolts must be min. 190 mm.
- The thickness of the concrete floor slab for M 16 x 105 HVC dynamic anchor bolts must be min. 210 mm.
- The concrete floor slab must be horizontal and even.
- The concrete quality must meet min. B25 or C20/25.
- Mounting with through bolts consisting of base plate, through bolts and counter plates (for ceiling thicknesses up to 350 mm).
- Floor/wall mounting or floor/ceiling mounting on request.

INFO

Plate dimensions, quantity, dimension and position of the chemical anchors depend on the crane type, load capacity and boom length of the crane (details and technical data according to the relevant crane data sheet).

Due to cable sag, we recommend that on low cranes festooned cables be used, even for a short boom length.

Base plate for fastening pillar-mounted slewing jibs and slewing cranes without foundation

Some pillar-mounted slewing jibs and slewing cranes can be mounted by means of a standard base plate or an dowel base plate. No foundation is required, easy and quick assembly on the customer's existing reinforced concrete slab is possible. **Potential tripping hazard by protruding locknuts, unmarked or unsecured plate edges must be clearly marked.**



- The installation location of the crane must be selected in such a way that the base plate is mounted outside of traffic routes according to the German regulations for workplaces ASiV para. 2. If this is not possible, the plate must be secured or marked in such a way that a hazard is avoided (e.g. by warning hatching along the edge of the plate).
- The base plate with tripping points must not protrude into escape routes or limit their prescribed min. widths.
- The measures for reducing hazards caused by tripping points must be taken by the operating company in cooperation with the safety expert.
- A warning sign as hazard reduction is a minimal measure and may not be sufficient in certain cases (e.g. in spite of warning signs, tripping incidences occur frequently, the warning sign is not recognised sufficiently in advance).

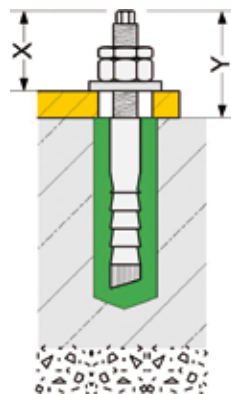

The smallest possible projection of the chemical anchor over the crane base plate "X" with an M12 anchor is approx. 33 mm, with M16 approx. 37 mm. This dimension can only be reached, if the concrete floor slab exceeds the above-mentioned min. thickness. The max. projection of the chemical anchor, measured

from floor level "Y", is approx. 73 mm for M12 anchors and approx. 86 mm for M16 anchors, with the relevant min. floor slab thickness.

TDL

Moveable gantry crane

Yalesystems gantry crane for use in all areas, from craftsman's workshops, garages and industrial use. They are suitable for low to medium weight capacities and are also for outdoor use.

The cranes are moved by hand and are not dependant on a rail system.

The guidelines for moving Yalesystems gantry cranes and transporting loads should be strictly followed.

Optional

- Increased paint layer (120 µm) or hot-dip galvanisation for outdoor use.
- Hoist cover for outdoor use.
- Parking brake by threaded spindle.
- Power supply by festooned cables incl. flat cables, C type mounting rail, cable trolley, support arms and towing trolleys.



Scope of delivery

- 3-part construction with 2 robust rectangular steel-bar supports and 1 load carrier beam.
- Manually moveable
- Cranes are supplied with an operating manual and complete manufacturer's documentation.

INFO

Further capacities and boom lengths on request.

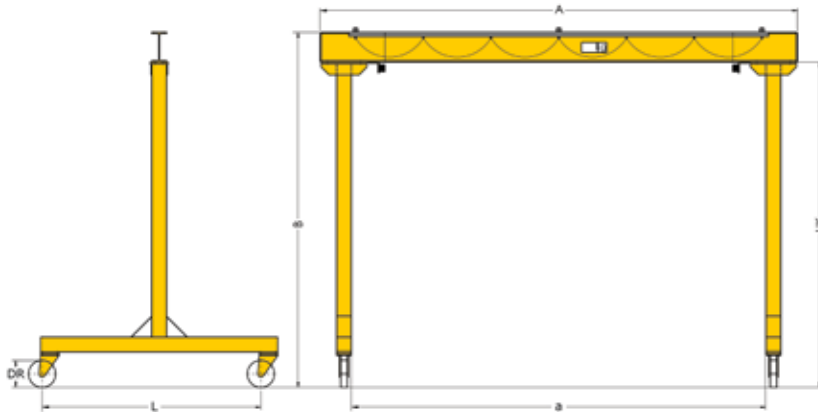

Standard delivery programme TDL

Model	Capacity kg	Boom length in mm							
		2500	3000	3500	4000	4500	5000	5500	6000
TDL 500	500	•	•	•	•	•	•	•	•
TDL 1000	1000	•	•	•	•	•	•	•	•
TDL 2000	2000	•	•	•	•	•	•	•	•
TDL 3200	3200	•	•	•	•	•	•	•	•

Boom clearance (UK): Standard 2500 mm, other dimensions on request.

Gantry width - inside (dimension a):

TDL-500/TDL-1000: Boom length A less 455 mm

TDL-2000/TDL-3000: Boom length A less 500 mm

Festooned cable system

The Yale festooned cable system kit contains all the parts necessary to install a power supply.

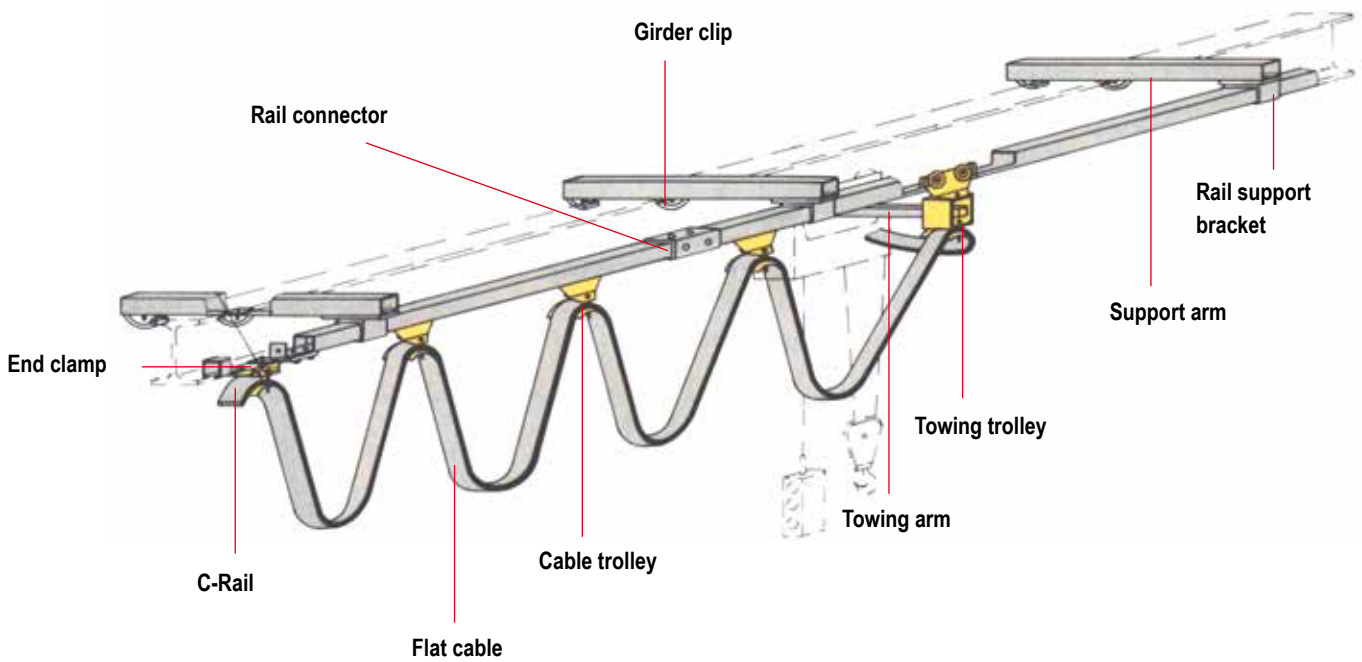

INFO

Quantity of units dependant on track length.

Features

- The PVC flat cable 4 x 2.5 mm² is suitable for all electric hoists with a power consumption of up to 25 A.
- The line sag is 700 mm. The cable and towing trolleys are made from plastic and can carry loads of up to 10 daN.
- The rollers are fitted with bronze bushes resp. ball bearings.
- The C-rail, rail support brackets and rail connectors are zinc-plated for added protection against corrosion.

Optional

- Mounting kit consisting of support arm and girder clips for connection to the beam.
- Towing arm for towing trolley.

Scope of delivery

- 1 end clamp
- 1 end stop
- 1 towing trolley
- 2 end caps
- 2 FI-fittings with locknuts
- 2 FI-fittings with locknuts 400 V, 50 Hz
- Two information signs according to UVV



Main switch

Scope of delivery festooned cable systems

Model	Art.-No.	Art.-No. Mounting kit	C-rails track length m	Transport distance max. m	PVC flat cable m	Cable trolleys	Rail support bracket	Rail connector	Rail connector
Festooned cable 4.0 m C-rail track length	N07700001	N07700010	4	3.5	9	2	4	0	
Festooned cable 6.0 m C-rail track length	N07700002	N07700011	6	5.4	11	3	5	1	
Festooned cable 8.0 m C-rail track length	N07700003	N07700012	8	7.3	13	5	6	1	
Festooned cable 10.0 m C-rail track length	N07700004	N07700013	10	9.2	15	6	7	2	
Festooned cable 12.0 m C-rail track length	N07700005	N07700014	12	11.0	17	8	8	2	
Festooned cable 14.0 m C-rail track length	N07700006	N07700015	14	12.9	19	9	9	3	
Festooned cable 16.0 m C-rail track length	N07700007	N07700016	16	14.8	21	11	10	3	
Festooned cable 18.0 m C-rail track length	N07700008	N07700017	18	16.7	23	12	11	4	
Festooned cable 20.0 m C-rail track length	N07700009	N07700018	20	18.5	25	14	12	4	



Cable trolley



Towing trolley



Rail support bracket



Rail connector



C-Rail

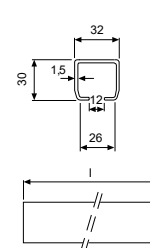
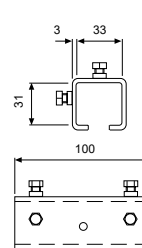
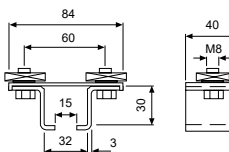
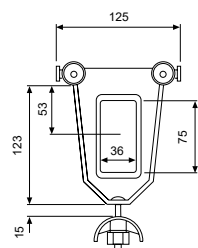
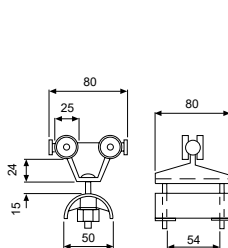

INFO

Optional: Mounting kit consisting of support arm and girder clips for connection to the beam.

Special applications e.g. for curves or cable trolley for round cables on request.

