

# TeleMotion Receiver Supplement for *telePilot*<sup>™</sup> and *telePendant*<sup>™</sup> Transmitters

## Programming the *telePilot* or *telePendant* for use with a TeleMotion receiver.

Your system comes preprogrammed and programming should be unnecessary. However, if you do wish to program the unit the following steps are needed.

Step 1. Familiarize your self with the use of the PDA in programming the *telePilot* transmitter by reading the programming section of the *telePilot* manual.

Step 2. using the PDA select "Tx Type" "2 SPD *telePilot*" or "2 SPD *telePendant*" depending on which transmitter is used.

Step 3. Select the appropriate Bank.

Step 4. Under "System" select "10K" for the *telePilot*, the 2 SPD *telePendant* defaults to 10K.

Step 5. Input Frequency code.

Step 6. Input Receiver Access Code.

Step 7. Tap "Save" and load program into the appropriate transmitter.

telePilot Programmer

Tx Type ▼ 2 SPD telePilot

Use bank password

First press ▼ Button 6  
 Second press ▼ Button 5  
 Third press ▼ Button 4  
 Fourth press ▼ Button 3

Bank 1 Bank 2 Bank 3 Bank 4  
 off off off off

Name: ..... M

Setup Bank #

System ▼ 10K Freq ▼ AK01

A1 [0-9] B1 [0-9]

Receiver access code

Multibox  
 Auto Turn Off

S3-1 [0-9] Timer ▼ 15

Switch conf.: H,T,B

Main/Aux ▼ Aux

Save Cancel

Setup Bank #

System ▼ 10K Freq ▼ AK01

A1 [0-9] B1 [0-9]

Receiver access code

Multibox  
 Auto Turn Off

S3-1 [0-9] Timer ▼ 15

Switch conf.: H,T,B

Main/Aux ▼ Aux

Save Cancel

# TeleMotion Wiring Diagram for *telePilot* and *telePendant* Transmitters.

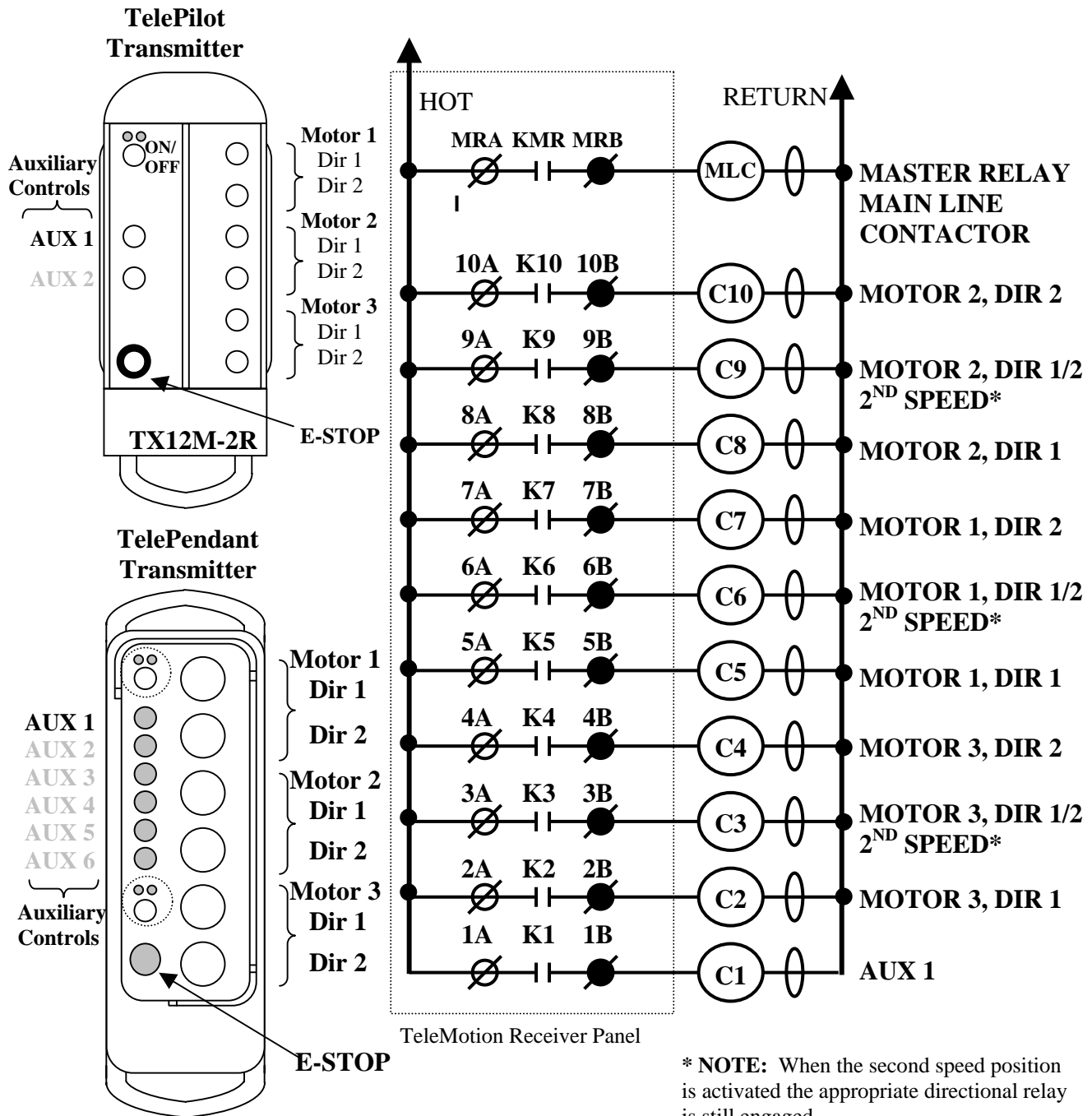

\* NOTE: When the second speed position is activated the appropriate directional relay is still engaged.

