

**OPERATION, SERVICE  
& PARTS MANUAL**

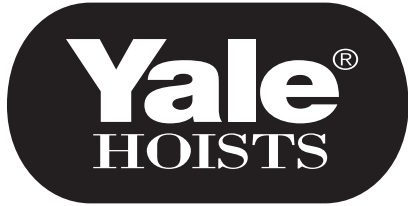

# **STRUCTURAL TUBE ROTATING AXLE END TRUCKS**

**WHEEL SIZES: 9", 12", 15" & 18"**

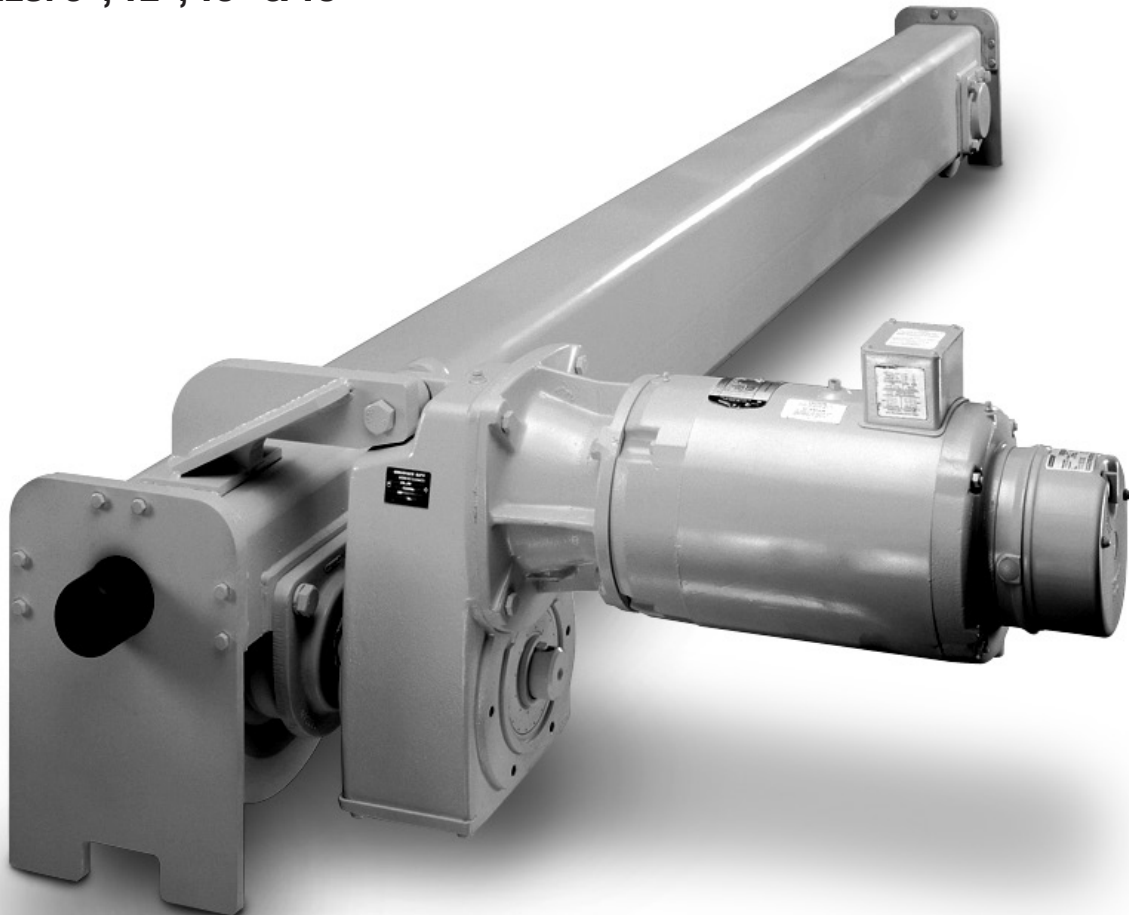

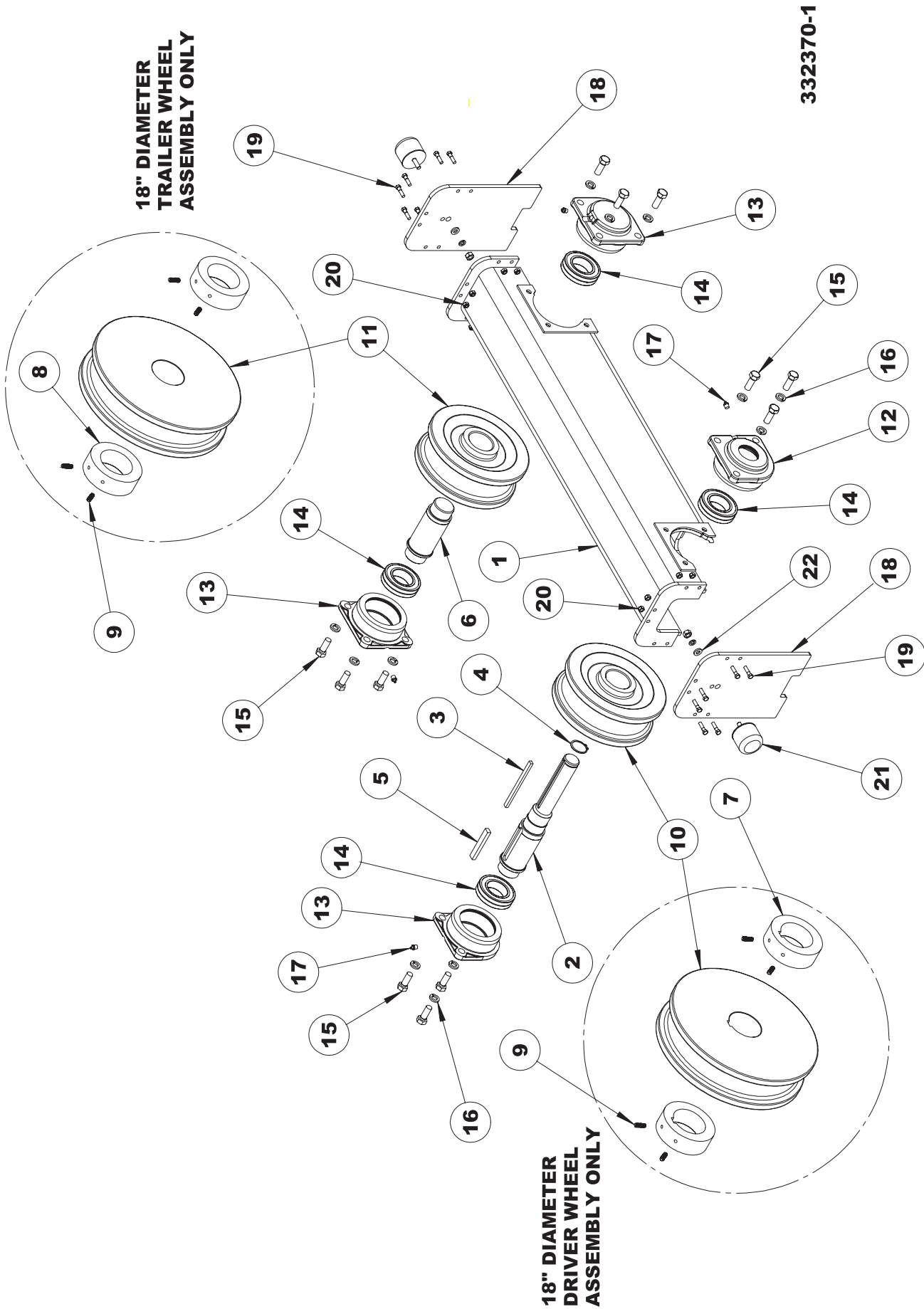

**ROTATING AXLE END TRUCK PARTS BREAKDOWN**

# ROTATING AXLE END TRUCK PARTS LIST

Reference No.	Component Description	Quantity Required*	Truck Wheel Diameter				
			9" Key No.	12" Key No.	15" Key No.	18" Key No.	
1	Truck Tube Weldment (Order by wheelbase (in.))	42	1	TRT-1001	TRT-1021	TRT-1051	TRT-1081
		48		TRT-1002	TRT-1022	TRT-1052	TRT-1082
		54		TRT-1003	TRT-1023	TRT-1053	TRT-1083
		60		TRT-1004	TRT-1024	TRT-1054	TRT-1084
		66		TRT-1005	TRT-1025	TRT-1055	TRT-1085
		72		TRT-1006	TRT-1026	TRT-1056	TRT-1086
		78		TRT-1007	TRT-1027	TRT-1057	TRT-1087
		84		TRT-1008	TRT-1028	TRT-1058	TRT-1088
		90		TRT-1009	TRT-1029	TRT-1059	TRT-1089
		96		TRT-1010	TRT-1030	TRT-1060	TRT-1090
		102		TRT-1011	TRT-1031	TRT-1061	TRT-1091
		108		TRT-1012	TRT-1032	TRT-1062	TRT-1092
		114		TRT-1013	TRT-1033	TRT-1063	TRT-1093
		120		TRT-1014	TRT-1034	TRT-1064	TRT-1094
		126			TRT-1035	TRT-1065	TRT-1095
		132			TRT-1036	TRT-1066	TRT-1096
		138			TRT-1037	TRT-1067	TRT-1097
		144			TRT-1038	TRT-1068	TRT-1098
		150			TRT-1039	TRT-1069	TRT-1099
		156			TRT-1040	TRT-1070	TRT-1100
162		TRT-1041	TRT-1071	TRT-1101			
168		TRT-1042	TRT-1072	TRT-1102			
174		TRT-1043	TRT-1073	TRT-1103			
2	Driver Axle (Order by reducer)	LT2282	1	TRT-1111	TRT-1121		
		LT3282		TRT-1112	TRT-1122	TRT-1131	
		LT4282			TRT-1123	TRT-1132	TRT-1141
		LT5282			TRT-1124	TRT-1133	TRT-1142
		LT6282				TRT-1134	TRT-1143
		LT7282					TRT-1144
		Center Drive			TRT-1113	TRT-1125	TRT-1135
3	Reducer Key (Order by reducer)	LT2282	1	TRT-1151	TRT-1161		
		LT3282		TRT-1152	TRT-1162	TRT-1171	
		LT4282			TRT-1163	TRT-1172	TRT-1181
		LT5282			TRT-1164	TRT-1173	TRT-1182
		LT6282				TRT-1174	TRT-1183
		LT7282					TRT-1184
		Center Drive			TRT-1153	TRT-1165	TRT-1175
4	Axle Retaining Ring (Order by reducer)	LT2282	1	TRT-1201	TRT-1211		
		LT3282		TRT-1202	TRT-1212	TRT-1221	
		LT4282			TRT-1213	TRT-1222	TRT-1231
		LT5282			TRT-1214	TRT-1223	TRT-1232
		LT6282				TRT-1224	TRT-1233
		LT7282					TRT-1234
		Center Drive					
5	Driver Wheel Key	1	TRT-1241	TRT-1242	TRT-1243	TRT-1244	
6	Trailer Axle	1	TRT-1251	TRT-1252	TRT-1253	TRT-1254	
7	Driver Wheel Spacer	2				TRT-1261	
8	Trailer Wheel Spacer	2				TRT-1262	
9	Self Locking Set Screw	8				TRT-1263	

\* Quantities listed are for one (1) complete end truck



# ROTATING AXLE END TRUCK PARTS LIST

Reference No.	Component Description	Quantity Required*	Truck Wheel Diameter				
			9"	12"	15"	18"	
			Key No.	Key No.	Key No.	Key No.	
10	Driver Wheel (Order by rail size & tread type)**	1	20#-30#, ST	TRT-1301			
			20#-30#, TT	TRT-1302			
			40#-60#, ST	TRT-1303			
			40#-60#, TT	TRT-1304			
			30#-50#, ST		TRT-1311	TRT-1321	TRT-1331
			30#-50#, TT		TRT-1312	TRT-1322	TRT-1332
			55#-105#, ST		TRT-1313	TRT-1323	TRT-1333
			55#-105#, TT		TRT-1314	TRT-1324	TRT-1334
11	Trailer Wheel (Order by rail size & tread type)**	1	20#-30#, ST	TRT-1401			
			20#-30#, TT	TRT-1402			
			40#-60#, ST	TRT-1403			
			40#-60#, TT	TRT-1404			
			30#-50#, ST		TRT-1411	TRT-1421	TRT-1431
			30#-50#, TT		TRT-1412	TRT-1422	TRT-1432
			55#-105#, ST		TRT-1413	TRT-1423	TRT-1433
			55#-105#, TT		TRT-1414	TRT-1424	TRT-1434
12	Bearing Cage with hole	1	TRT-1501	TRT-1502	TRT-1503	TRT-1504	
13	Bearing Cage w/o hole	3	TRT-1511	TRT-1512	TRT-1513	TRT-1514	
14	Wheel Bearing	4	TRT-1521	TRT-1522	TRT-1523	TRT-1524	
15	Bearing Cage Bolt	12	TRT-1531	TRT-1532	TRT-1533	TRT-1534	
16	Bearing Cage Lockwasher	12	TRT-1541	TRT-1542	TRT-1543	TRT-1544	
17	Lubrication Fitting	4	TRT-1551	TRT-1552	TRT-1553	TRT-1554	
18 **	Rail Sweep ( 20#-30# Rail)	2	TRT-1601				
	Rail Sweep ( 40#-60# Rail)		TRT-1602				
	Rail Sweep ( 30#-50# Rail)			TRT-1611	TRT-1621	TRT-1631	
	Rail Sweep ( 55#-105# Rail)			TRT-1612	TRT-1622	TRT-1632	
19	Rail Sweep Bolt	12	TRT-1651	TRT-1652	TRT-1653	TRT-1654	
20	Rail Sweep Locknut	12	TRT-1661	TRT-1662	TRT-1663	TRT-1664	
21	Bumpers (Includes nuts & lockwashers)	2	R3	TRT-1771	TRT-1771	TRT-1771	TRT-1771
			R4	TRT-1772	TRT-1772	TRT-1772	TRT-1772
			R5	TRT-1773	TRT-1773	TRT-1773	TRT-1773
			R6	TRT-1774	TRT-1774	TRT-1774	TRT-1774
			R7	TRT-1775	TRT-1775	TRT-1775	TRT-1775
			R8		TRT-1776	TRT-1776	TRT-1776
22	Flat Washers	2	R3	TRT-1781	TRT-1781	TRT-1781	TRT-1781
			R4	TRT-1782	TRT-1782	TRT-1782	TRT-1782
			R5	TRT-1783	TRT-1783	TRT-1783	TRT-1783
			R6	TRT-1784	TRT-1784	TRT-1784	TRT-1784
			R7	TRT-1785	TRT-1785	TRT-1785	TRT-1785
			R8		TRT-1786	TRT-1786	TRT-1786

\*\* ST = Straight Tread Wheels, TT = Tapered Tread Wheels

\*\* If bronze wheels or rail sweeps are required, follow the Key No. with a "B" for bronze.

For example, a 9" bronze driver wheel for 20#-30# rail with straight tread must be ordered as TRT-1301B

\* Quantities listed are for one (1) complete end truck



# ROTATING AXLE END TRUCK PARTS LIST

Reference No.*	Component Description		Quantity Required	9" Wheel	12" Wheel	15" Wheel	18" Wheel	
				Key No.	Key No.	Key No.	Key No.	
** Wheel Assemblies (Order by drive type, rail size, & tread type)	LT2282	20#-30#, ST	1	TRT-2001				
		20#-30#, TT		TRT-2002				
		40#-60#, ST		TRT-2003				
		40#-60#, TT		TRT-2004				
		30#-50#, ST	1		TRT-2055			
		30#-50#, TT			TRT-2056			
		55#-105#, ST			TRT-2057			
		55#-105#, TT			TRT-2058			
	LT3282	20#-30#, ST	1	TRT-2009				
		20#-30#, TT		TRT-2010				
		40#-60#, ST		TRT-2011				
		40#-60#, TT		TRT-2012				
		30#-50#, ST	1		TRT-2063	TRT-2113		
		30#-50#, TT			TRT-2064	TRT-2114		
		55#-105#, ST			TRT-2065	TRT-2115		
		55#-105#, TT			TRT-2066	TRT-2116		
	LT4282	30#-50#, ST	1		TRT-2067	TRT-2117	TRT-2167	
		30#-50#, TT			TRT-2068	TRT-2118	TRT-2168	
		55#-105#, ST			TRT-2069	TRT-2119	TRT-2169	
		55#-105#, TT			TRT-2070	TRT-2120	TRT-2170	
	LT5282	30#-50#, ST	1		TRT-2071	TRT-2121	TRT-2171	
		30#-50#, TT			TRT-2072	TRT-2122	TRT-2172	
		55#-105#, ST			TRT-2073	TRT-2123	TRT-2173	
		55#-105#, TT			TRT-2074	TRT-2124	TRT-2174	
	LT6282	30#-50#, ST	1			TRT-2125	TRT-2175	
		30#-50#, TT				TRT-2126	TRT-2176	
		55#-105#, ST				TRT-2127	TRT-2177	
		55#-105#, TT				TRT-2128	TRT-2178	
	LT7282	30#-50#, ST	1				TRT-2179	
		30#-50#, TT					TRT-2180	
		55#-105#, ST					TRT-2181	
		55#-105#, TT					TRT-2182	
	Est. driver wheel assembly wgt.				95#	235#	415#	635#
	Center Drive	20#-30#, ST	1	TRT-2035				
		20#-30#, TT		TRT-2036				
		40#-60#, ST		TRT-2037				
		40#-60#, TT		TRT-2038				
		30#-50#, ST			TRT-2089	TRT-2139	TRT-2189	
		30#-50#, TT			TRT-2090	TRT-2140	TRT-2190	
		55#-105#, ST			TRT-2091	TRT-2141	TRT-2191	
55#-105#, TT				TRT-2092	TRT-2142	TRT-2192		
Est. center wheel assembly wgt.				95#	235#	415#	635#	
Trailer Wheel Assembly	20#-30#, ST	1	TRT-2043					
	20#-30#, TT		TRT-2044					
	40#-60#, ST		TRT-2045					
	40#-60#, TT		TRT-2046					
	30#-50#, ST			TRT-2097	TRT-2147	TRT-2197		
	30#-50#, TT			TRT-2098	TRT-2148	TRT-2198		
	55#-105#, ST			TRT-2099	TRT-2149	TRT-2199		
	55#-105#, TT			TRT-2100	TRT-2150	TRT-2200		
Est. trailer wheel assembly wgt.				90#	225#	400#	625#	

\* Complete wheel assemblies must be ordered based upon drive type, rail size & tread type  
 Driver wheel assemblies include Reference No.'s 2-5, 7,9-10,12-14, 17 in the appropriate quantities.  
 Trailer wheel assemblies include Reference No.'s 6,8,9,11,13-14,17 in the appropriate quantities.  
 \*\* ST = Straight Tread Wheels, TT = Tapered Tread Wheels  
 \*\* If bronze wheel assembly is required, follow the Key No. with a "B" for bronze.

## LUBRICATION

Multipurpose grease may be used for lubricating the wheel bearings. Because environmental conditions may vary with each installation, the user should adjust the scheduled lubrication periods to provide adequate lubrication for the existing operating conditions and service.

For special conditions consult Columbus McKinnon Corporation for advice.

Also refer to CMAA 70 and ANSI/ASME 30.2 for additional information.

## SPARE PARTS

**Note:** When ordering parts always furnish Hoist Serial Number, Catalog Number, Motor Horsepower, Voltage, Phase, Frequency and Rated Load of Hoist on which the parts are to be used.

### PARTS AND SERVICES ARE AVAILABLE IN THE UNITED STATES AND IN CANADA

Parts for your hoist or trolley are available from your local authorized repair station. For the name of the nearest parts or service center, visit our website [www.cmworks.com](http://www.cmworks.com) or call the Columbus McKinnon customer service department at (800) 888-0985.

## WARNING

Non-factory authorizations or modification of equipment and use of commercial or other manufacturer's parts to repair end trucks may cause malfunction or loss of load.

### TO AVOID INJURY:

Do use only factory provided replacement parts. Parts may look alike but parts are made of specific materials and processes to achieve specific properties.

## WARNING

Reuse of set screws (reference no. 9) can cause damage to bearing!

### TO AVOID INJURY:

DO NOT REUSE SET SCREW. Use only factory supplied replacement set screws (TRT-1263)

# WARRANTY

## WARRANTY AND LIMITATION OF REMEDY AND LIABILITY

A. Seller warrants that its products and parts, when shipped, and operating (including installation, construction and start-up), when performed, will meet applicable specifications, will be of good quality and will be free from defects in material and workmanship. All claims for defective mechanical components under this warranty must be made in writing immediately upon discovery and in any event, within three (3) years from shipment of the applicable item unless Seller specifically assumes installation, construction or start-up responsibility. All claims for defective mechanical components when Seller assumes installation, construction or start-up responsibility and all claims for defective work must be made in writing immediately upon discovery and in any event, within three (3) years from completion of the applicable work by Seller, provided; however, all claims for defective mechanical components must be made in writing no later than (42) months after shipment. All claims for defective electrical components under this warranty must be made in writing immediately upon discovery and in any event, within one (1) year from shipment of the applicable item unless Seller specifically assumes installation, construction or start-up responsibility. All claims for defective electrical components when Seller assumes installation, construction or start-up responsibility and all claims for defective work must be made in writing immediately upon discovery and in any event, within one (1) year from completion of the applicable work by Seller, provided; however, all claims for defective electrical components must be made in writing no later than eighteen (18) months after shipment. Defective items must be held for Seller's inspection and returned to the original f.o.b. point upon request. THE FOREGOING IS EXPRESSLY IN LIEU OF ALL OTHER WARRANTIES WHATSOEVER, EXPRESS, IMPLIED AND STATUTORY, INCLUDING, WITHOUT LIMITATION, THE IMPLIED WARRANTIES OF MERCHANTABILITY AND FITNESS FOR A PARTICULAR PURPOSE. IN NO EVENT SHALL SELLER BE LIABLE TO BUYER OR ANY THIRD PARTY WITH RESPECT TO ANY GOOD, WHETHER

IN CONTRACT, TORT OR OTHER THEORY OF LAW, FOR LOSS OF PROFITS OR LOSS OF USE, OR FOR ANY INCIDENTAL, CONSEQUENTIAL, SPECIAL, DIRECT OR INDIRECT DAMAGES, HOWSOEVER CAUSED.

B. Upon Buyer's submission of a claim as provided above and its substantiation, Seller shall at its option either (i) repair or replace its product, part or work at either the original f.o.b. point of delivery or at Seller's authorized service station nearest Buyer; or (ii) refund an equitable portion of the purchase price. All claims are to be submitted in accordance with our published warranty process.

C. This warranty is contingent upon Buyer's proper maintenance and care of Seller's products, and does not extend to normal wear and tear. Seller reserves the right to void warranty in event of Buyer's use of inappropriate materials or application in the course of repair or maintenance, or if Seller's products have been dismantled prior to submission to Seller for warranty inspection at Seller's authorized service station.

D. Seller shall not be liable for any damage, injury or loss arising out of the use of the goods if, prior to such damage, injury or loss, such goods are: (i) damaged or misused following Seller's delivery to the carrier; (ii) not maintained, inspected, or used in compliance with applicable law and Seller's written instructions and recommendations; (iii) installed, repaired, altered or modified without compliance with such laws, instructions or recommendations; or (4) repaired with parts or accessories other than those supplied by CMCO.

E. The foregoing is Seller's only obligation and Buyer's exclusive remedy for breach of warranty and is Buyer's exclusive remedy hereunder by way of breach of contract, tort, strict liability or otherwise. Any action for breach of this agreement must be commenced within one (1) year after the cause of action has accrued.





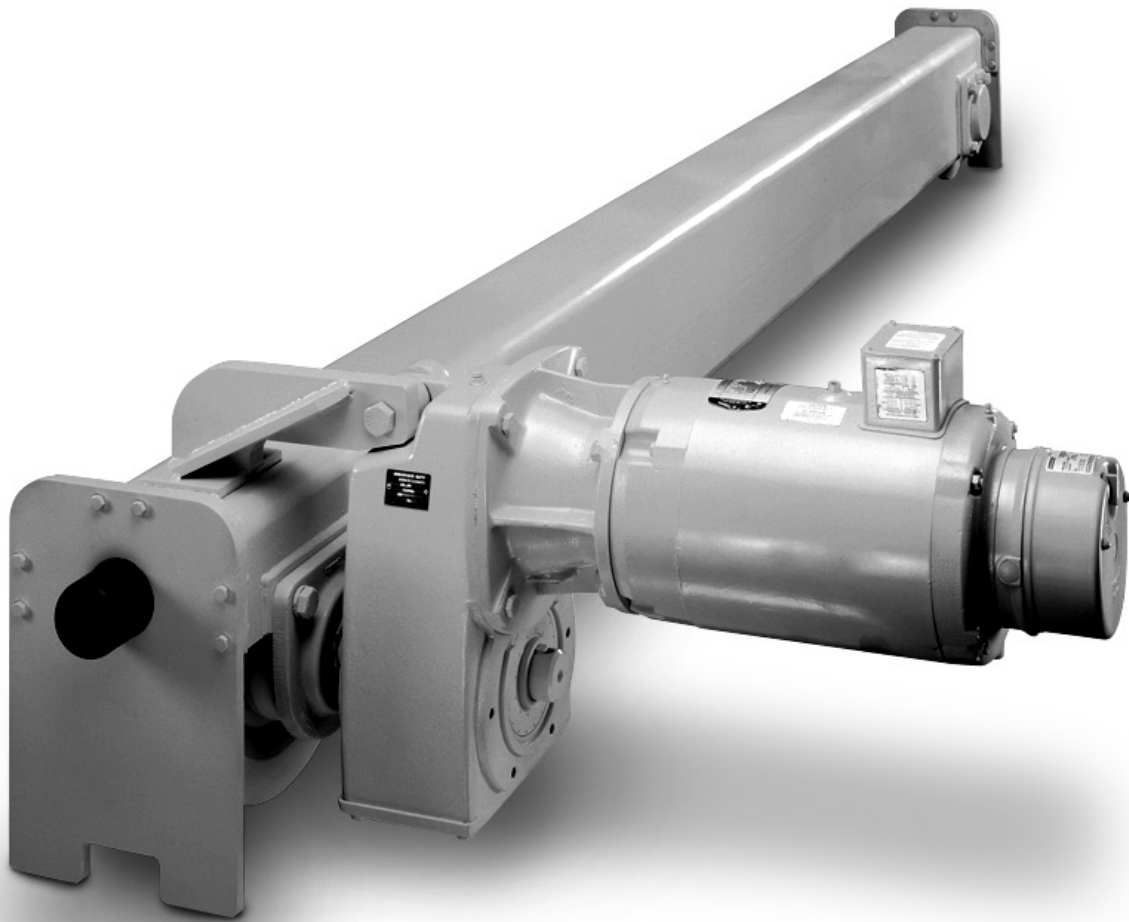

COLUMBUS MCKINNON  
CORPORATION

FAMILY OF BRANDS



Phone (800) 888.0985 • (716) 689.5400 • Fax: (716) 689.5644 • [www.cmworks.com](http://www.cmworks.com)