

BATTERYSTAR

BATTERY POWERED CHAIN HOIST



POWERED BY



READY WHEN YOU ARE

Do you need the lifting strength and speed of an electric chain hoist and power is not available or the portability of a manual hoist without the time-consuming effort of manually operating the hoist? Then turn to the Yale® BatteryStar™ Battery Powered Chain hoist built with industry-leading technology from Columbus McKinnon and Milwaukee Tool®. Designed for portability and easy installation, the BatteryStar can have you lifting in minutes – simply attach the hoist to an anchor point, slide in a battery, and you’re ready to go!

Powered by an industry-leading M18™ Red Lithium Battery from Milwaukee Tool®, the BatteryStar is built for heavy-duty lifting and uses the same M18™ battery you may already have on your job site for added convenience.

Designed for safety and ease of use, the BatteryStar is controlled by a wireless remote to keep the operator out of the load path. The remote also features built-in intelligence, alerting the operator of an overload situation or if hoist inspection is due.*

Whether you’re lifting materials at a construction site or moving equipment into place for an outdoor concert, the BatteryStar has the power and speed you need for any application – especially when external power is not available.

*Hoist inspection light is based on the recommended annual hoist inspection for normal use. Refer to the operator’s manual for inspection recommendations by application. Hoist inspection indication requires the use of ONE-KEY™.



Compact-size hoist



Battery inside



Wireless control

WHICH HOIST & WHEN

	Hand chain hoist	Yale® BatteryStar™	Power chain hoist
Portability	portable	portable	heavy/stationary
Energy/Power	manual pull power	battery, no cabling	needs cabling for power supply
Cost	low	medium	high
Speed/Efficiency	low	medium	high



Outdoor use where power is not available.

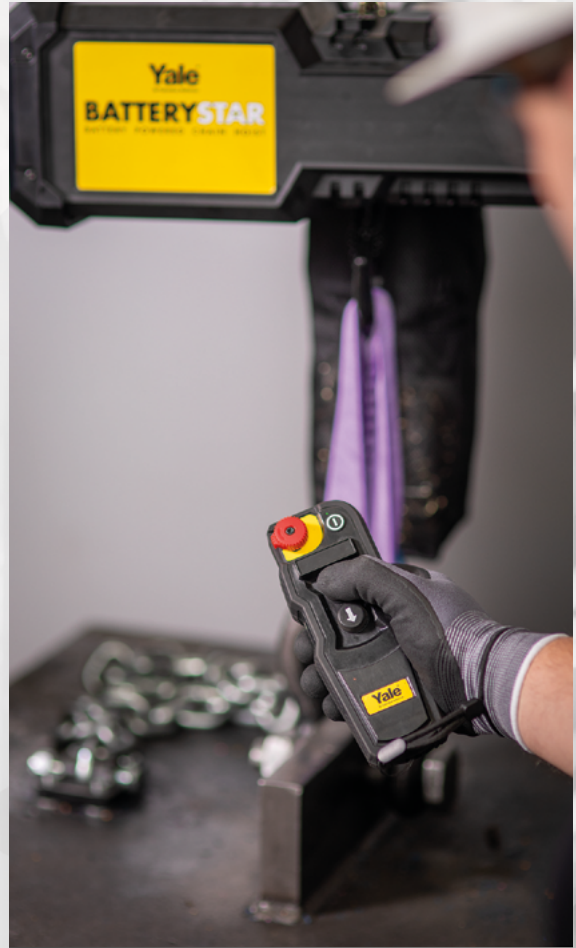

Stepless speed allows precise load positioning.



Horizontal pulling by remote control, also in places without power supply.



Portable hoist for heavy duty lifting.

FEATURES AND BENEFITS

Capacity: 1,000 kg | **Lift:** 6 m | **Lift Speed:** 2.4 m/min | Completely wireless | Safe mechanical brake



NO ELECTRIC POWER REQUIRED

- Operates on battery power, specifically a Milwaukee Tool® brand M18™ battery, making it ideal for applications or areas where electricity is unavailable or difficult to reach.
- Provides lifting speeds up to 2.4 m/min, helping increase operator efficiency as much as 4x compared to using a manual hoist.

PORTABILITY

- Weighing 19,8 kg when 6 m of chain is included (less battery), the BatteryStar is compact and lightweight for easy portability.
- Optional road/carrying cases available.



VERSATILE OPERATION

- Hoist can be used in either with the hoist body attached to the anchor point or inverted.
- Inverted operation eliminates the need to carry the weight of the hoist up to the anchor point. Just carry the hook up to the anchor point and let the hoist lift itself and the load up.

DURABILITY & RELIABILITY

- Electronic clutch and secondary mechanical clutch provide dual protection from hoist overload.
- Integrated limit switch for the highest and lowest hook position considerably extends the service life of the slip clutch, motor and gearbox.
- Electronics are IP55 rated.

QUICK & EASY INSTALLATION

- Lightweight and portable, the BatteryStar can be easily attached to an anchor point, then you're ready to lift. No cords or power is required.
- Simply snap a charged battery into place, and the hoist is ready to operate.

PRECISE LIFTING

- Hoist offers true variable speed, allowing for precise lifting and lowering in any application.



PATENT-PENDING BRAKE

- With a patent-pending design, the mechanical brake automatically activates when lowering the load, providing safe operation.
- Brake inspection windows on the top and bottom of the hoist allow operators to easily check brake wear, helping to facilitate preventative maintenance.



LONG HOIST & CHAIN LIFE

- Rugged composite hoist cover designed for durability in rough conditions.
- Brushless DC motor for extended hoist life.
- Zinc-plated load chain for protection against corrosion.





OTHER FEATURES

- FEM 1Cm rated.
- EC Conformity.
- Chain bag provided as standard. The chain bag tilts automatically in case of inverted application.



SAFE, REMOTE OPERATION

- Remote buttons allow for true variable speed – the further you push the button, the faster the lifting speed. This allows the operator to precisely position the load.
- Wireless remote keeps the operator safe and away from the load, allowing for operation from over 20 m away from the hoist.
- Remote features built-in intelligence, alerting the operator with light-up icons:

-  Low Battery
-  Overcapacity
-  Over-Temperature Warning
-  Inspection Reminder*

- Rugged and durable, the remote is IP55 rated and can stand up to the harsh conditions of any worksite.
- Remote is easy to connect. Features a light to show that connection is in progress, and the hoist makes an audible sound when connection is complete.
- Standard stop button easily disables the remote.
- Remote includes a lanyard to prevent the operator from dropping it during operation and a belt clip for easy portability.
- RF-certified.

*Hoist inspection light is based on the recommended annual hoist inspection for normal use. Refer to the operator's manual for inspection recommendations by application. Hoist inspection indication requires the use of One-Key™. (see operation manual for details)

FEATURES AND BENEFITS

TRUSTED, HIGH-QUALITY BATTERY

- Supplied battery is fully compatible with more than 250 Milwaukee Tool® products utilizing M18™ batteries for added convenience on the job site.
- Unique patented designs protect every REDLITHIUM™ Battery, safeguarding your investment through drops, weather exposure, and harsh environments.

PERMANENT SOUND PRESSURE LEVEL

The equivalent permanent sound pressure level at the workplace of the operating staff is ≤ 75 dB. It was determined with the use of the measurement surface sound pressure level method (distance from lifting device 1 m, 9 measuring points, precision class 2 DIN 45635).



HOOK TRAVEL DISTANCE BY LOAD CAPACITY

- How long the BatteryStar can run on one battery charge depends on the load that is applied on the hoist's hook. The smaller the loads, the longer the hoist can operate without recharging the battery.
- This chart gives you a rough idea of how many meters the BatteryStar can run on one battery charge when loads smaller than 1 tonne are moved.

Battery	Capacity	Hook Travel*
12.0 Ah Battery	250 kg	145 m
	500 kg	90 m
	750 kg	67 m
	1,000 kg	55 m

* Estimated total travel with equal lifting and lowering.

WHAT HAPPENS SHOULD THE BATTERY RUN LOW



This icon on the wireless remote will warn you (slowly flashing red) when the battery has only 25% residual charge when using the recommended 12Ah battery. Recharge or replace the battery to ensure continued operation.

If the battery runs out of power during operation and the hoist stops operating:

- Simply open the battery compartment and remove the battery, then insert a charged battery.
- Otherwise, in an emergency, open the end compartment and lower the load with a power drill.

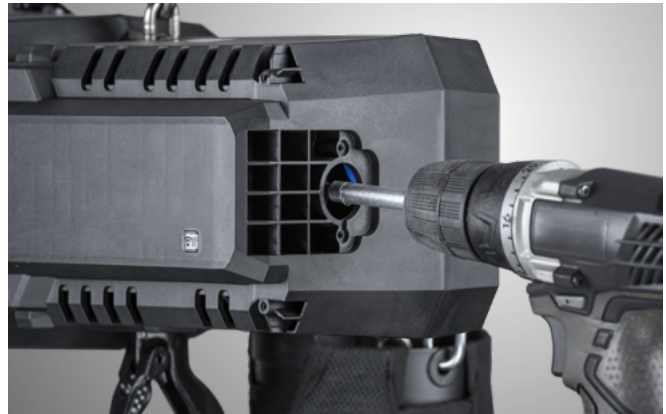

MILWAUKEE TOOL® ONE KEY™

BatteryStar hoist includes Milwaukee Tool® ONE-KEY™* that allows you to:

- Connect your hoist and other smart tools to your job site for easy asset management and tracking
- Access to equipment information from your computer or smartphone with an easy-to-use app and interface.
- Inspection interval feature to set reminders and store records of hoist inspections.
- To use this feature, download the ONE-KEY™ app from the App Store® or Google Play™ on your smart device and follow the instructions in our Manual.



PART NUMBERS AND DIMENSIONS

Product Number	Battery and Charger included	Suspension Type	Capacity	Hoist Speed	Lift
CBCY1008R202	no	Rigid Hook	1,000 kg	2.4 m/min	6 m
CBCY1008R201EM	yes, charger with EU plug		1,000 kg	2.4 m/min	6 m
CBCY1008R201UK	yes, charger with UK plug		1,000 kg	2.4 m/min	6 m
CBCY1008S202	no	Swivel Hook	1,000 kg	2.4 m/min	6 m
CBCY1008S201EM	yes, charger with EU plug		1,000 kg	2.4 m/min	6 m
CBCY1008S201UK	yes, charger with UK plug		1,000 kg	2.4 m/min	6 m

*Other chain lengths can be ordered at request.

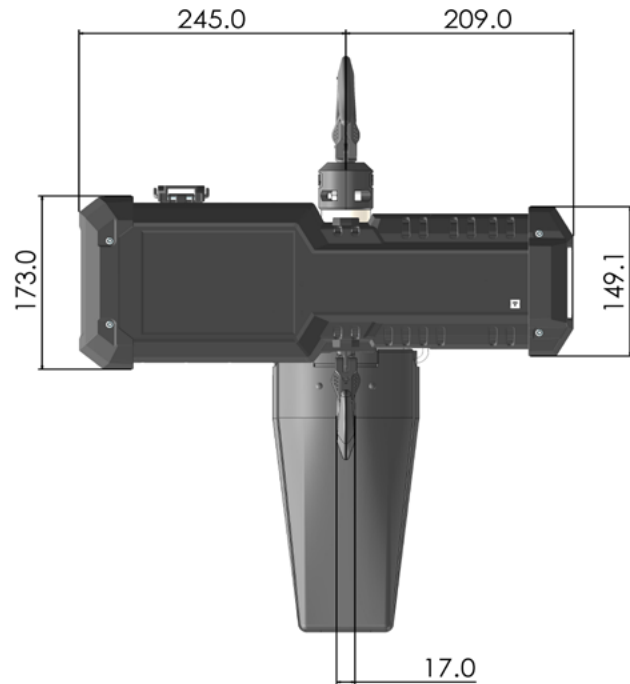
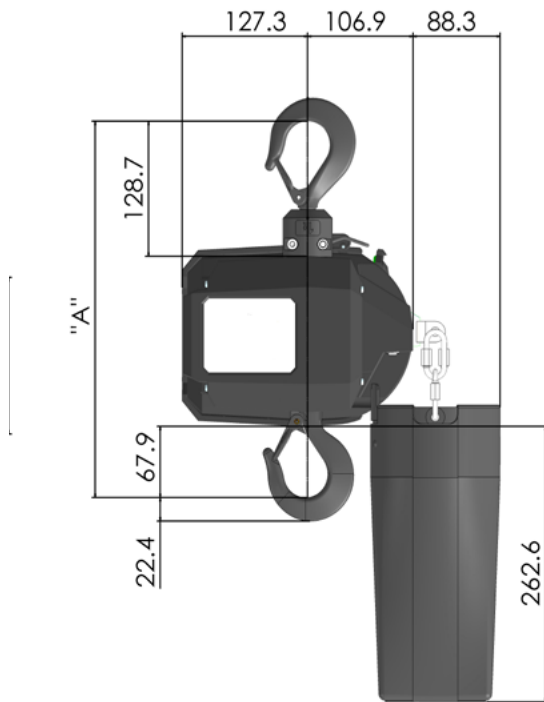

HEADROOM

Hook Type	Dimension "A" (mm)
Rigid	371
Swivel	401

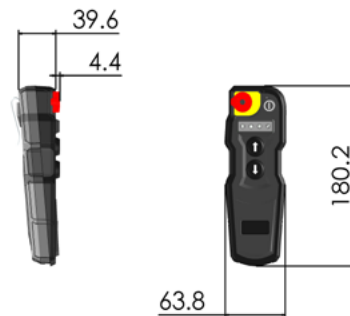



CMCO
INTELLIGENT MOTION
Columbus McKinnon



Visit: www.cmco.com

Follow:     

Columbus McKinnon EMEA GmbH | Yale-Allee 30 | 42329 Wuppertal | Germany | Tel +49 202 693 59-0 | info.wuppertal@cmco.eu | www.cmco.com

© 2024 Columbus McKinnon. All Rights Reserved.

Milwaukee Tool®, M18™, and ONE-KEY™ are trademarks of Milwaukee Tool Company | 15.02.2024
Subject to engineering changes and improvements. No warranty for printing errors or mistakes.